

Astraada One Compact HMI Prime



Trademarks

- CANtrol®// is a registered trademark.
- Microsoft®, Windows® and the Windows® logo are registered trademarks belonging to the Microsoft Corp. in the USA and in other countries.
- EtherCAT® is a registered trademark and patented technology licensed from Beckhoff Automation GmbH, Germany.
- CiA® and CANopen® are registered trademarks belonging to CAN in Automation e. V.
- ARM® and Cortex® are registered trademarks belonging to ARM Limited.
- PROFINET® is a registered trademark belonging to PROFIBUS user organization e. V.
- Modbus® is a registered trademark belonging to the Modbus-IDA Organisation.
- i.MX6 is a registered trademark belonging to NXP Semiconductors.

The rights of all companies and company names as well as products and product names mentioned in this website belong to the respective companies.

Notes on this user manual

This device user manual contains information which is specific to the product and which is valid at the time of printing.

This manual is only complete in conjunction with the product-related hardware and software user manuals required for the individual application.

You can reach us at:

ASTOR Sp. z o.o.

ul. Smoleńsk 29

31-112 Kraków

Poland

T: 12 428 63 00

E-mail: info@astor.com.pl

<https://www.astor.com.pl/>

Astraada One Compact HMI Prime is certified according to DIN EN ISO 9001: 2000.

Change log

Version	Date	Description
0.1	11.11.2019	HB first draft with new format and new numbers
0.9	05.06.2020	Pre-release
1.0	18.06.2020	Formatting of the document revised
1.1	13.10.2020	Address correction
1.2	05.03.2021	Dual Core versions added
1.3	16.09.2022	Cyber security added
1.4	12.12.2022	Additional Warning notice + installation instruction
1.5	23.01.2023	Correction temperature values; Supplement RMA process; Consumption, Cyber-security, Nameplate
1.6	25.09.2023	Adaption Cyber security

Table of contents

1.	GENERAL INFORMATION	7
1.1.	Notes on the manual	7
1.2.	Symbols and visual depictions	8
1.3.	Hazard categories and indications	8
1.4.	Qualified personnel	9
1.5.	Duty of care	9
1.5.1.	General	9
1.6.	Intended use	10
1.7.	Transport and storage	10
	Transport and storage	10
	Devices with batteries/rechargeable batteries	11
	Operation	11
1.8.	Unpacking	11
2.	SAFETY	12
2.1.	Safety related systems	12
2.2.	Safety instructions	12
	Working on the device	13
2.3.	Cybersecurity	13
3.	PRODUCT DESCRIPTION	14
3.1.	Overview	15
3.2.	Scope of delivery and accessories	16
	Scope of delivery	16
	Accessories	16
3.3.	Product features	16
	Installation	16
	Processor	16
	Ethernet interface	16
	EtherCAT interface	16
	USB interface	16
	CAN interface	17
	Serial interface	17
	Onboard inputs / outputs	17
	Real Time Clock	17
	microSD card	17
	Summary of features	17
4.	INSTALLATION	18

4.1.	Preparation for front installation Astraada One Compact HMI Prime 7	18
4.2.	Preparation for front installation Astraada One Compact HMI Prime 10.....	20
4.3.	Preparation for front installation Astraada One Compact HMI Prime 15.....	22
4.4.	Assembly.....	24
5.	CONNECTION.....	26
5.1.	Power supply.....	26
	Internal power supply	26
	Installation.....	26
5.1.1.	Connecting the power supply.....	27
5.2.	Data connections	29
5.2.1.	Block circuit diagram Astraada One Compact HMI Prime 7/10/15	29
5.2.2.	Digital inputs and outputs	30
5.2.3.	Counter inputs (C)	34
	Examples for counters: Up/Down; Pulse/Direction; Encoder (A/B).....	34
	Example for a counter: Capture input or counter input	35
	Data for the counting inputs	35
	Installation instructions	35
5.2.4.	Analogue inputs (only S02 – S05)	36
	Basic considerations for analogue inputs	36
	Data from analogue inputs.....	37
	Operating modes for the analogue inputs.....	37
	Voltage input AI (U)	41
	Temperature measurement AI (T).....	42
	2-wire measurement.....	42
	3-wire measurement.....	42
5.2.5.	Ethernet interface	42
5.2.6.	EtherCAT interface	44
5.2.7.	USB interface.....	45
5.2.8.	CAN interface (only S03 – S05)	46
5.2.9.	Serial interfaces (only S04 – S05).....	47
	Signal interference and terminating resistor	48
	Connections with GND	48
6.	OPERATION	49
6.1.	Switching on and off	49
	Switching on	49
	Switching off.....	49
6.2.	Initial Setup of the device	50
6.2.1.	Web Terminal Configuration	50
6.2.2.	On-Screen Configuration	52
6.2.3.	Status indicators.....	54
	Location of the status LEDs.....	54
	Meaning of the LEDs.....	54

6.2.4.	Function key S1	55
6.2.5.	Real Time Clock	55
	Setting the date and time.....	55
	Changing the battery.....	55
6.2.6.	microSD card (only S03 – S05)	56
	Inserting a microSD card.....	56
6.3.	Troubleshooting	57
6.3.1.	No network connection	57
6.3.2.	CODESYS application is in Error Stop	57
7.	MAINTENANCE AND SERVICE	58
7.1.	Maintenance	58
7.2.	Cleaning	58
8.	UNINSTALLATION	59
9.	DISPOSAL	61
	Disposal by the manufacturer	61
	Disposal in accordance with regional regulations.....	61
10.	INFORMATION AND OPTIONS	62
10.1.	Nameplate	66
10.2.	Device variations and identification	67
10.3.	Options and Add-ons	68
11.	STANDARDS AND CERTIFICATES	69
11.1.	Standards	69
	Applicable directives	69
	Applicable standards	69
12.	APPENDIX.....	70
12.1.	Information on copyright and software licence	70

1. General information

This user manual is intended for use by qualified professionals and contains information on the assembly, installation, start-up and maintenance of the device.

1.1. Notes on the manual

This manual is a component of the product and applies to the following devices:

- ➔ Astraada One Compact HMI Prime 7 S01 – S05
- ➔ Astraada One Compact HMI Prime 10 S01 – S05
- ➔ Astraada One Compact HMI Prime 15 S01 – S05

The manual contains information on the following topics:

- ➔ Applications
 - ➔ Safety
 - ➔ Mechanical design
 - ➔ Electrical design
 - ➔ Connections
 - ➔ Start-up
 - ➔ Upkeep and maintenance
 - ➔ Decommissioning
 - ➔ Disposal
- ▶ Always keep this user handbook available alongside the product.

1.2. Symbols and visual depictions

The following symbols and visual depictions are used in this handbook:

Symbol	Meaning
→ ...	List entry
▶ ...	Individual instruction or list of instructions which can be carried out in any order.
1. ... 2. ...	List of instructions which must be carried out in the order given.
	Additional product information

Design of warnings:

WARNING

Optional:	Hazard type and source
Other	Short description and consequences
Symbols	▶ Preventive measures

1.3. Hazard categories and indications

The following indications are used in the case of warning messages so as to ensure your personal safety and avoid any damage to property.

The indications have the following meanings:

DANGER

Serious injury or death

Non-compliance with the safety features will result in death or serious injury.

- ▶ Take preventive measures.

WARNING

Possible serious injury or death

Non-compliance with the safety features may result in death or serious injury.

- ▶ Take preventive measures.

CAUTION

Possible minor injuries

Non-compliance with the safety features may result in minor injuries.

- ▶ Take preventive measures.

NOTE

Possible damage to property

Non-compliance with the safety features may result in damage to property.

- ▶ Take preventive measures.
-

1.4. Qualified personnel

The installation, start-up and maintenance of the device must be carried out by qualified personnel.

For the purposes of this documentation and the safety instructions contained therein, “qualified personnel” means trained staff who are familiar with safety concepts in automation engineering and who are authorised to assemble, install, start up, earth and identify devices, systems and electrical circuits in accordance with standards set in safety engineering.

1.5. Duty of care

1.5.1. General

The user (OEM) must ensure the following:

- The device must only be used according to regulations.
- The device must only be used in good working order.
- The user handbook must always be kept legible and fully available.
- Only sufficiently qualified and authorised personnel may carry out the assembly, installation, start-up and maintenance of the device.
- These authorised personnel must receive regular training on all relevant occupational health and safety and environmental protection issues and must be fully familiar with the contents of this user handbook, particularly the sections regarding safety features.
- Any markings or identification labels and safety and warning signs on the device must not be removed and must be kept legible at all times.
- The national and international regulations regarding the operating of machinery and facilities where the device is being used must be observed at all times.
- The user must always be kept abreast of any current relevant information regarding the device and its use or operation.

The user takes direct responsibility for agreeing with the competent authorities the use of safety-related control components, and for compliance with their instructions.

1.6. Intended use

The device is part of a modular automation system for industrial control applications within the medium to high performance range. It extends the communications capabilities to include EtherCAT, Profinet, Modbus and others.

The automation system is designed for use within overvoltage category I (IEC 364 4 443) systems for controlling and regulating machinery and industrial processes in low-voltage installations in accordance with the following general parameters:

- ➔ maximum rated supply voltage of 1,000 V AC (50/60 Hz) or 1,500 V DC
- ➔ Environment with maximum category 2 pollution (EN 61010-1)
- ➔ for use up to a maximum altitude of 2,000 m above msn.
- ➔ for indoor use only in areas not exposed to direct UV radiation
- ➔ Max. ambient temperature inside and outside the control cabinet in accordance with the technical data (see " ")

Qualified project planning and design, proper transport, storage, installation, use and careful maintenance are essential to the flawless and safe operation of the automation system.

The automation system may only be used within the scope of the data and applications specified in this documentation and associated user manuals.

The automation system must only be used:

- ➔ as intended
 - ➔ in a technically perfect condition
 - ➔ without any unauthorised modifications
 - ➔ by qualified users
-
- ▶ Observe the rules of the employer's liability insurance association, the technical inspectorate, and the VDE (Association of German Electrical Engineers) or corresponding country regulations.
 - ▶ The device is intended for installation into a suitable cut-out on industrial machines and systems in indoor areas.
 - ▶ When installing the device, check that the seal profiles are undamaged
 - ▶ For operation, refer to the applicable statement of ambient conditions (see " ").

1.7. Transport and storage

The device is susceptible to impacts, heavy vibration, moisture and extreme temperatures.

Transport and storage

- ▶ Protect the device against major mechanical stresses during transport.
- ▶ Always pack the device in its original packaging for transport.
- ▶ For storage, refer to the applicable statement of ambient conditions (see ".").
- ▶ Protect the device against condensation and damp.

Devices with batteries/rechargeable batteries

Lithium metal batteries are hazardous items. The manufacturer's information specifies that they are subject to UN 3091 (must be permanently installed within the device).

The ADR 188 special regulations can be applied for transport.

Operation

- ▶ If the device has been stored or transported in cold weather or under conditions or large fluctuations in temperature, do not start to operate it until it has acclimatised to room temperature for the place it is used.
- ▶ If condensation is present, wait at least 12 hours before starting to operate the device.

1.8. Unpacking

On receipt of the device, a check must be made that it is complete and undamaged.

- ▶ Check the packaging for external damage.
- ▶ If the packaging is seriously damaged or if damage to the contents is evident: Do not proceed further with opening the packaging, instead immediately inform the transport company and your supplier.
- ▶ Remove the packaging and keep it safe for subsequent transport.
- ▶ Check the contents for evidence of damage in transport.
- ▶ Check the contents for completeness against the order documentation and keep all the delivery documentation for future reference. The delivery documentation contains important information about the device and is part of the product.
- ▶ If you discover damage in transport, or if the equipment delivered does not match the order: Inform the supplier immediately.

2. Safety

2.1. Safety related systems

The use of PLCs in safety-related systems requires specific measures. Wherever a PLC is to be used in a safety-related system, the user must be given comprehensive advice by the PLC manufacturer in addition to information on any available standards or regulations regarding safety installations.

- ▶ Before starting any work on devices, switch off all power feeds, including to peripherals.
- ▶ Keep all ventilation holes unobstructed.

Failure in certain components in an electronic control system may result in uncontrolled and/or unpredictable operational behaviour.

- ▶ All types of failure must be considered at the system level and the associated preventative measures identified.
- ▶ If necessary, request information from your automation system provider.

2.2. Safety instructions

CAUTION

Possible minor injuries and/or burning of the surface of the skin

Non-compliance with the safety features may result in minor injuries / burning of the surface of the skin

The device may be operated only when it is in good working order. Exposed sharp edges or broken glass pose an injury risk.

- ▶ If you discover damage to the front glass of the device, do not continue to operate the device. Immediately disconnect it from the power supply.

The device may heat up during operation, especially in hot environments, because of the passive cooling mechanism of the electronics inside. The surface temperature may be high enough to cause burning if there is prolonged contact with the human skin.

- ▶ If possible, avoid touching the rear panel of the device during operation.
 - ▶ If you plan to work on e.g. the installation or cabling of the device, first shut it down by disconnecting the power supply and let it cool down for a while.
 - ▶ It is recommended to wear personal protective equipment, e.g. protective gloves when handling the warmed up device.
-

Working on the device

Do not start work on the device until all necessary safety precautions have been taken. Take precautions to avoid unforeseeable functional events and movements of the system.

- ▶ Bring the system into a safe condition.
- ▶ Switch the system and the device off.
- ▶ Secure the system against being switched on again.
- ▶ Disconnect the device from the system.

The casing of the device must not be opened.

- ▶ If work on the internal parts of the device is necessary or you do suspect some defects or damage, please contact the manufacturer (see "Addresses").

2.3. Cybersecurity

- ▶ Never place the control unit on the Internet without additional protection mechanisms, this product is not designed for this purpose
- ▶ Change the default passwords specified on delivery
- ▶ Always use an upstream external firewall to prevent access from the outside to the inside.
- ▶ Use the security mechanisms of VPN server portals (e.g. IXON) to which the controller can actively connect via VPN or comparable mechanisms
- ▶ Always use https instead of http
- ▶ Deactivate unnecessary services such as (FTP/SSH/Webserver)

3. Product description

The 7, 10 and 15 inches Dialog Controllers belonging to the Astraada One Compact HMI Prime family are control modules with a display for the control and regulation of automation and industrial processes in low-voltage installations in real time.

The CODESYS 3.5 (IEC 61131-3) development environment from 3S-Smart Software Solutions is used for programming the device.

The device connection area for all external connections is located at the rear of the devices. These devices are intended for installation on a flat surface in a pre-prepared installation cut-out.
All connections are of the plug-in type.

3.1. Overview

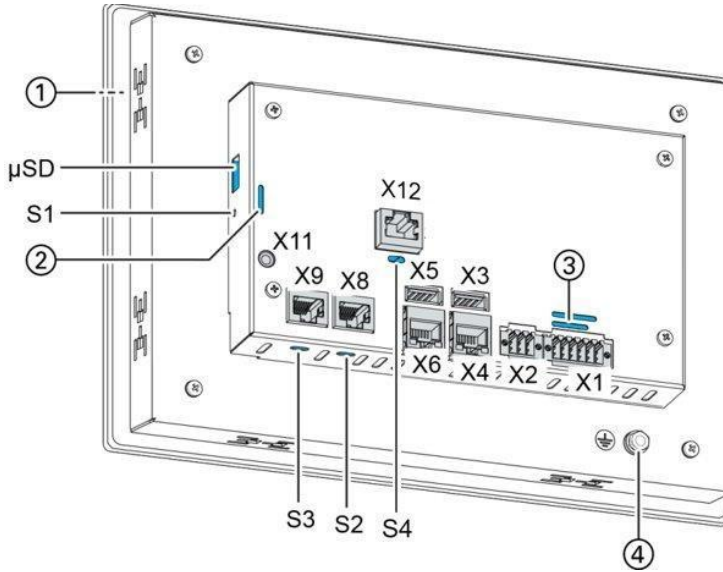

Fig. 11: Overview Astraada One Compact HMI Prime 7/10/15 (rear view)

Item	Designation	Item	Designation
1	Display 7, 10.1 or 15.6 inch	X8	CAN bus [CAN0]
2	LEDs: Power, Run/Stop, Error	X9	RS-232 [COM1] / RS-485 [COM2]
3	LEDs: Power, digital I/O	X11	Debug interface (do not use - only for Service Engineers)
4	Earth connection	X12	CAN bus [CAN1] (only version S05)
X1	Power supply, digital inputs/outputs	S1	Function key (Reset and Run/Stop)
X2	Analogue inputs	S2	Terminating resistor CAN [CAN0] (120 Ohm)
X3	USB 2.0	S3	Terminating resistor RS-485 [COM2] (120 Ohm)
X4	Ethernet [ETH0] ¹	S4	Terminating resistor CAN [CAN1] (120 Ohm) (only version S05)
X5	USB 2.0	μSD	MicroSD card slot
X6	EtherCAT [ETH1], also configurable as Ethernet		

¹ Terms in [] are the CODESYS designations of the interfaces

3.2. Scope of delivery and accessories

Scope of delivery

- Astraada One Compact HMI Prime Device
- Securing clip (6/8/14, depending on the device)

Accessories

The following accessories can be ordered using the device options (For more information read: Options and Add-ons)

- E-I/O connector, 12-pin (2x6), black Order n°. S-02020201-0601 or 204804700
- Securing clips, Order n°. S-02060201-0100 or 2P0500100

3.3. Product features

Installation

The device is designed for installation in a front panel or in a control panel in a rough industrial environment.

Processor

In its the basic configuration the device is equipped with an 800 MHz ARM® CPU with a Cortex™-A9 core.

Ethernet interface

1 Ethernet interface with 10/100 Mbit/s

The Ethernet interface is used for standard Ethernet connections. TCP/IP and UDP/IP protocols permit flexible connections to visualisation software, higher-level control units and to the IT infrastructure.

EtherCAT interface

The second Ethernet interface can be used as an EtherCAT master interface.

Other protocols available for the Ethernet interfaces: PROFINET, Ethernet/IP, OPC UA, BACnet and Modbus.

USB interface

The USB host interface allows a wide range of peripherals to be connected to the device. This allows a USB stick to be used for updating the application or for downloading data directly.



USB sticks with FAT/FAT32 formatting are supported.

If you require support for other USB formats, please contact our Technical Support.

CAN interface

The device has one standard CAN interface which can be used at speeds up to 1 Mbit/s.

Serial interface

The device has 2 serial ports (1 x RS-485; 1 x RS-232).

Onboard inputs / outputs

The device provides digital inputs, digital outputs and analogue inputs.

Real Time Clock

A battery-buffered, maintenance free real time clock can be used within the CODESYS application via a software interface.

microSD card

The standard commercial microSD card interface (SDHC up to max. 32 GB) allows data to be written to memory cards or read from memory cards.

Summary of features

- ARM® CPU with Cortex™-A9 single-core (800 MHz; optional dual or quad core)
- Program memory and data memory (RAM): 512 MB on-board
- Program memory (flash): 2048 MB on-board
- 2 USB host interfaces (USB 2.0)
- Retain memory 100 kB
- 2 Ethernet 10/100 Base T interfaces (2nd Interface: EtherCAT master interface)
- up to 2 CAN interfaces
- 2 serial interfaces (1 x RS-485; 1 x RS-232)
- 1 μSD card slot
- Onboard I/O
- Real Time Clock (RTC)

4. Installation

4.1. Preparation for front installation Astraada One Compact HMI Prime 7

The device is intended for installation from the front into a rectangular cut-out on a panel. The support material must be rigid and be from 1 to 3 mm thick.

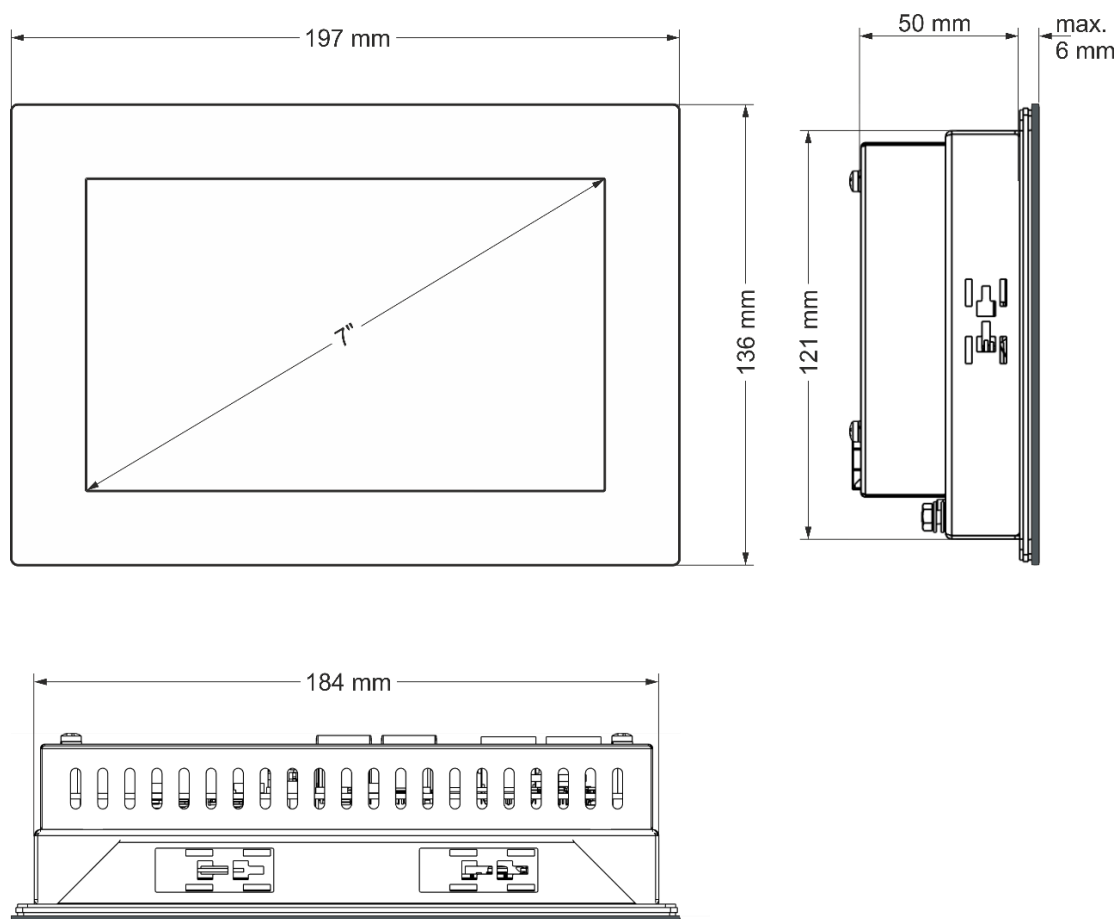

Fig. 22: Dimension Astraada One Compact HMI Prime 7

Requirements:

- ➔ To allow sufficient air circulation, it must be ensured that the device has a clear space of at least 20 mm all round at the rear.
- ➔ The max. ambient temperature inside the control cabinet must not exceed 55 °C Single Core, 50 °C Dual Core, in operation.
- ➔ The support material for the installation cut-out must be flat, sufficiently stable, and be from 1 to 3 mm thick.

NOTE

Damage to the device!

Installation on uneven support material can lead to mechanical stresses and cracks in the front face or malfunctioning of the touch screen.

- ▶ Make sure that the mounting points of the device are all in a common plane, with no more than maximum ± 0.5 mm variation.

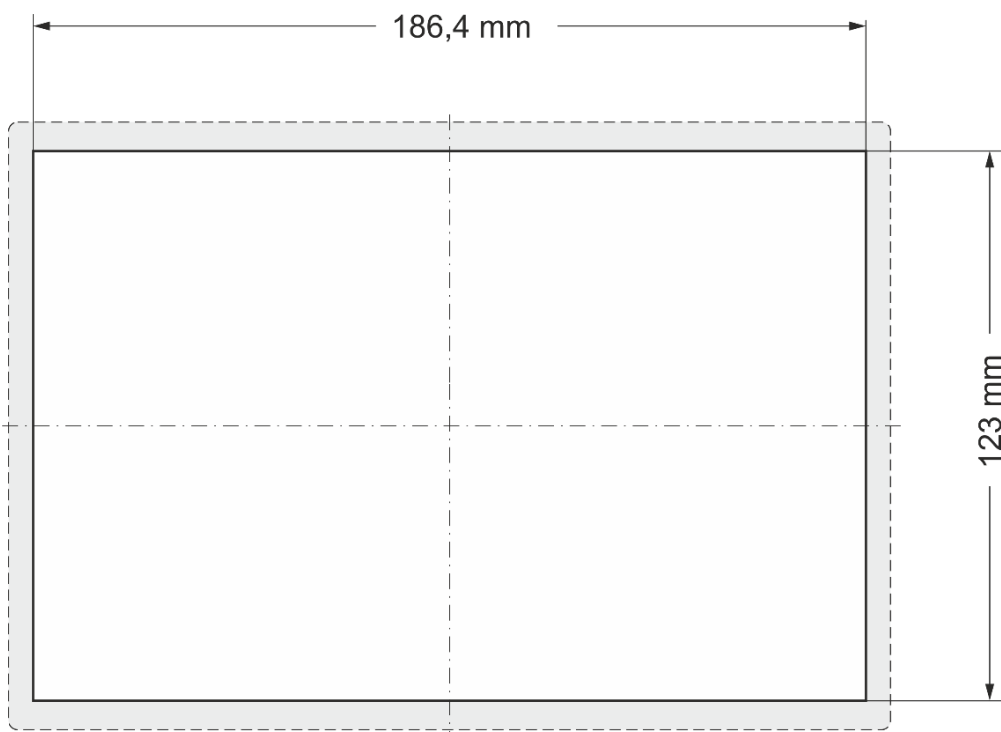

Fig. 33: Installation cut-out Astraada One Compact HMI Prime 10

- ▶ Cut a rectangular installation cut-out in the support material:
 - Height: 123 mm
 - Width: 186.4 mm
 - Max. corner radius: 1.5 mm



Optimum thickness of the support material: 1.0 mm to 3.0 mm

4.2. Preparation for front installation Astraada One Compact HMI Prime 10

The device is intended for installation from the front into a rectangular cut-out on a panel. The support material must be rigid and be from 1 to 3 mm thick.

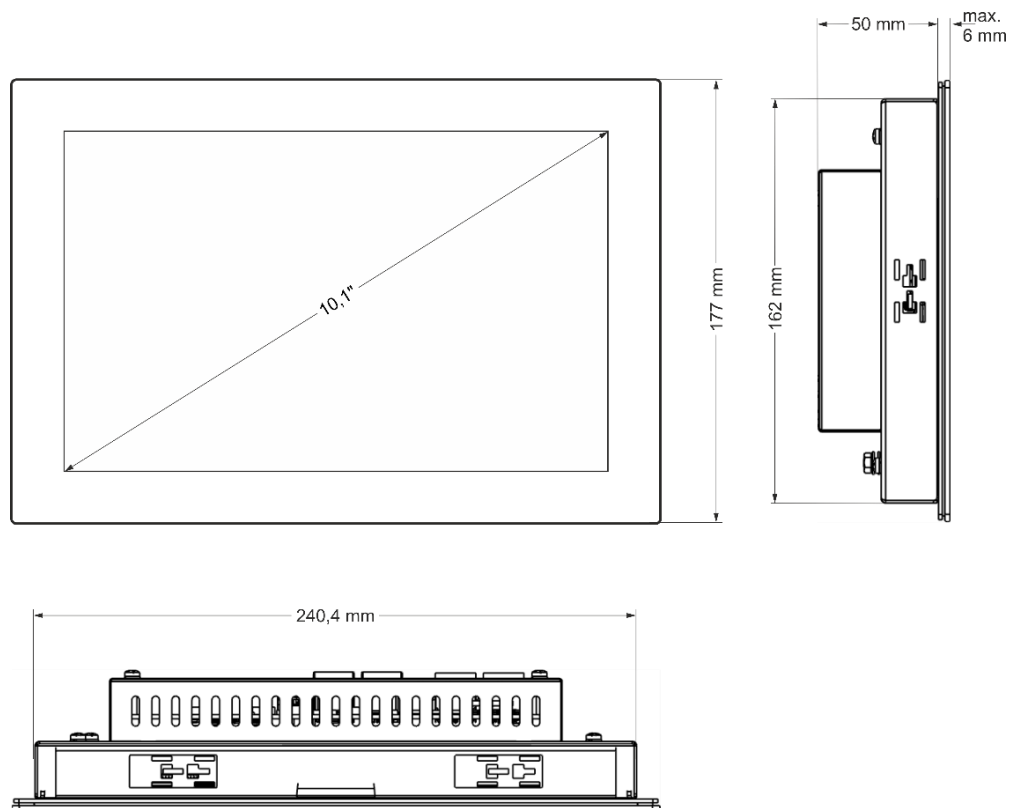

Fig. 44: Dimension Astraada One Compact HMI Prime 10

Requirements:

- ➔ To allow sufficient air circulation, it must be ensured that the device has a clear space of at least 20 mm all round at the rear.
- ➔ The max. ambient temperature inside the control cabinet must not exceed 55 °C in operation.
- ➔ The support material for the installation cut-out must be flat, sufficiently stable, and be from 1 to 3 mm thick.

NOTE

Damage to the device!

Installation on uneven support material can lead to mechanical stresses and cracks in the front face or malfunctioning of the touch screen.

- ▶ Make sure that the mounting points of the device are all in a common plane, with no more than maximum ± 0.5 mm variation.

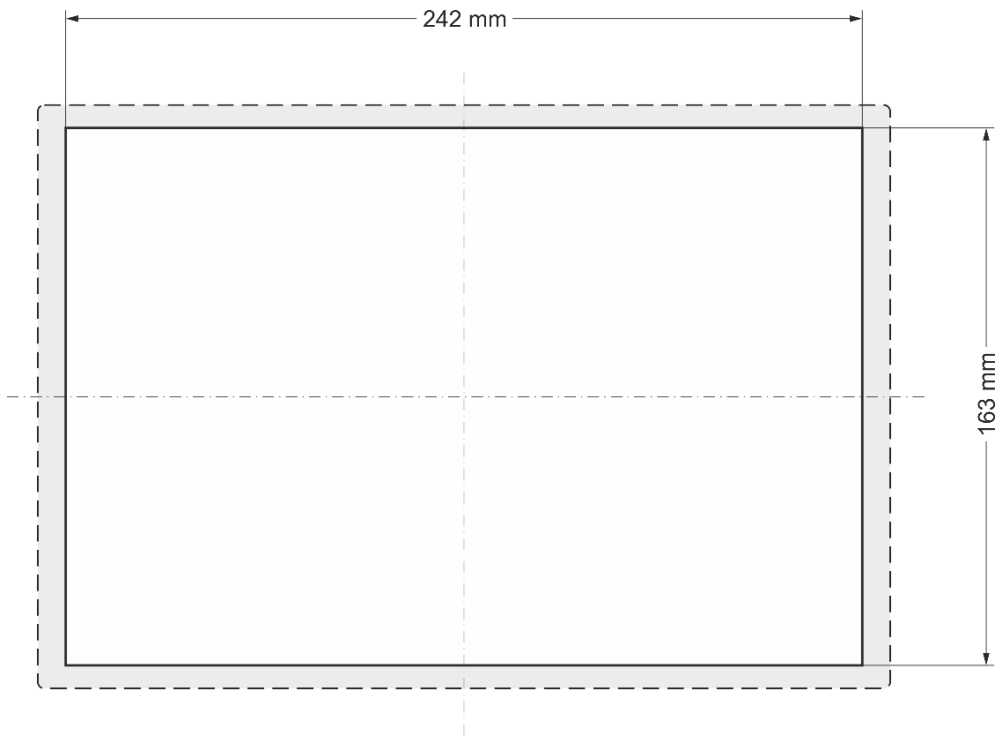

Fig. 55: Installation cut-out Astraada One Compact HMI Prime 10

- ▶ Cut a rectangular installation cut-out in the support material:
Height: 163 mm
Width: 242 mm
Max. corner radius: 1.5 mm

i Optimum thickness of the support material:
1.0 to 3.0 mm

4.3. Preparation for front installation Astraada One Compact HMI Prime 15

The device is intended for installation from the front into a rectangular cut-out on a panel. The support material must be rigid and be from 1 to 3 mm thick.

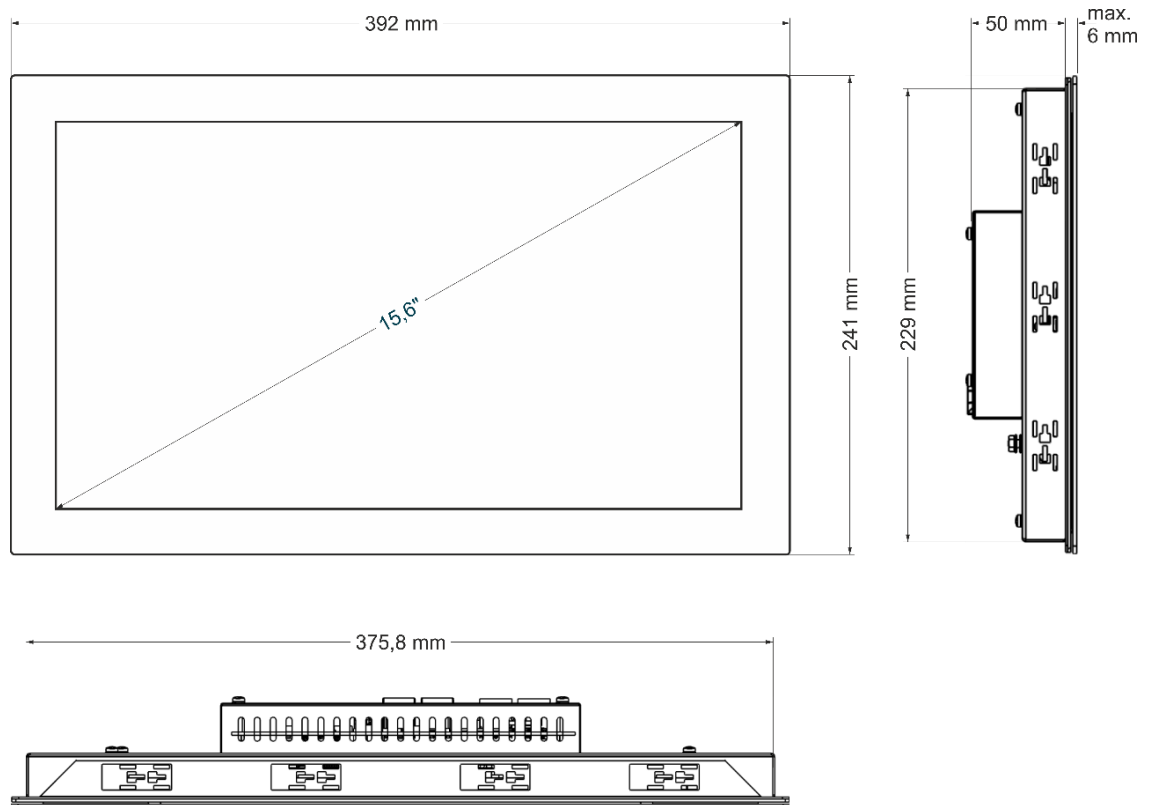

Fig. 66: Dimension Astraada One Compact HMI Prime 15

Requirements:

- ➔ To allow sufficient air circulation, it must be ensured that the device has a clear space of at least 20 mm all round at the rear.
- ➔ The max. ambient temperature inside the control cabinet must not exceed 55 °C in operation.
- ➔ The support material for the installation cut-out must be flat, sufficiently stable, and be from 1 to 3 mm thick.

NOTE

Damage to the device!

Installation on uneven support material can lead to mechanical stresses and cracks in the front face or malfunctioning of the touch screen.

- ▶ Make sure that the mounting points of the device are all in a common plane, with no more than maximum ± 0.5 mm variation.

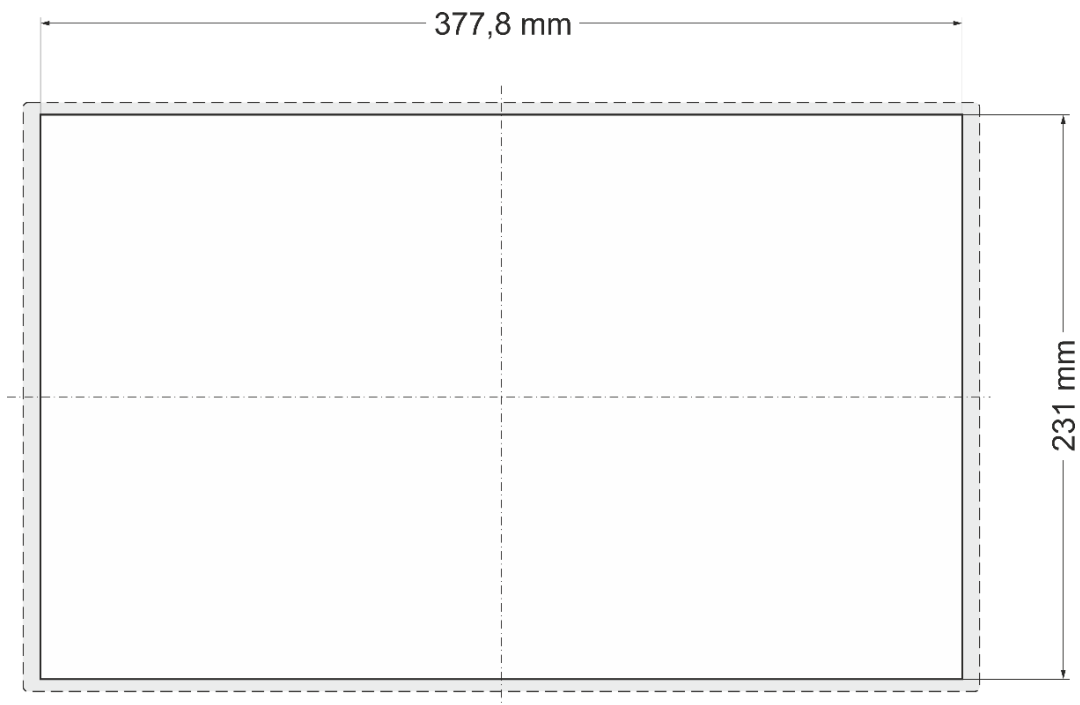

Fig. 77: Installation cut-out Astraada One Compact HMI Prime 15

- ▶ Cut a rectangular installation cut-out in the support material:
Height: 231 mm
Width: 377.8 mm
Max. corner radius: 1.5 mm

i Optimum thickness of the support material:
1.0 mm to 3.0 mm

4.4. Assembly

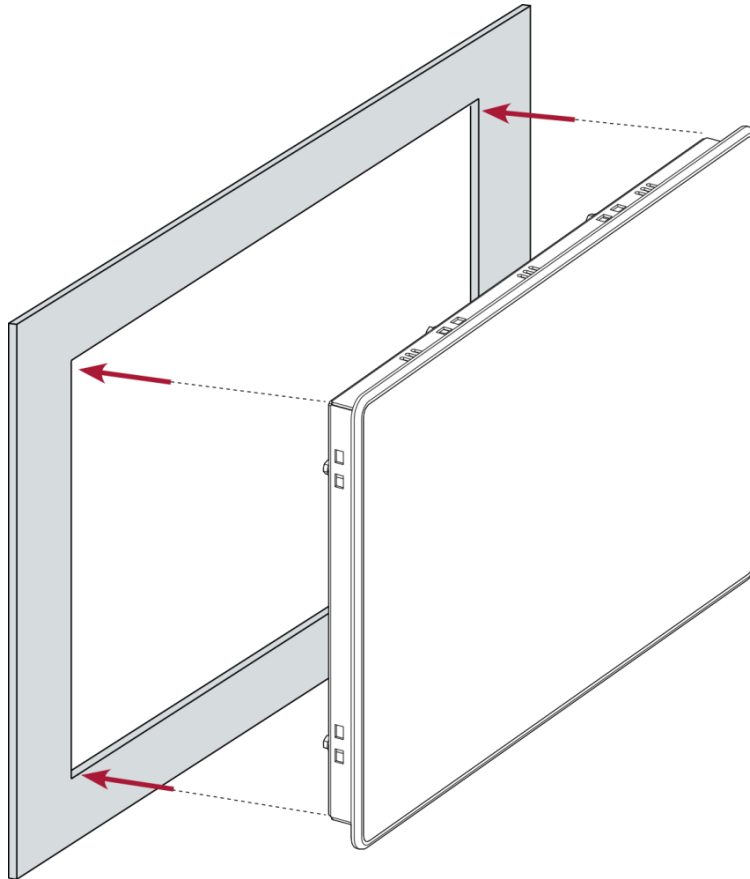

Fig. 88: Insertion into the installation cut-out

Requirements:

➔ The securing clips must not be attached to the device.

1. Making sure the alignment is correct, push the device evenly into the installation cut-out.

NOTE

Damage to the device!

If installation is performed carelessly the device can fall out of the installation cut-out or be damaged.

- ▶ Do not tilt the device.
- ▶ Restrain the device against falling until the securing clips have been tightened.

2. Make sure the device lies flush all round.

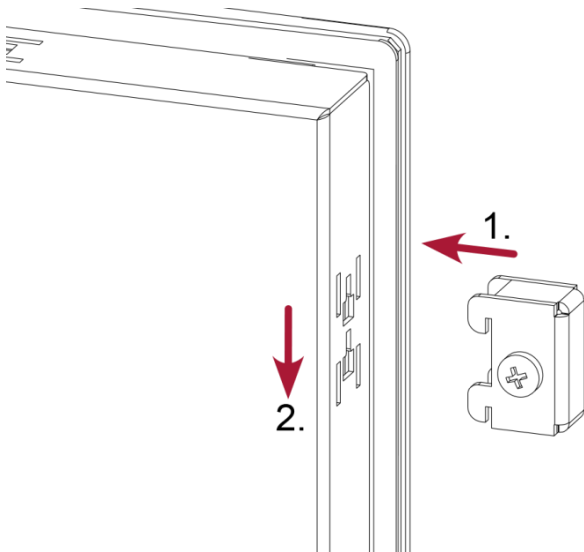

Fig. 99: Mounting the securing clips

3. Secure the device with 2 securing clips: Insert the securing clips into the cover at diagonally opposite points and tighten the screws finger-tight.

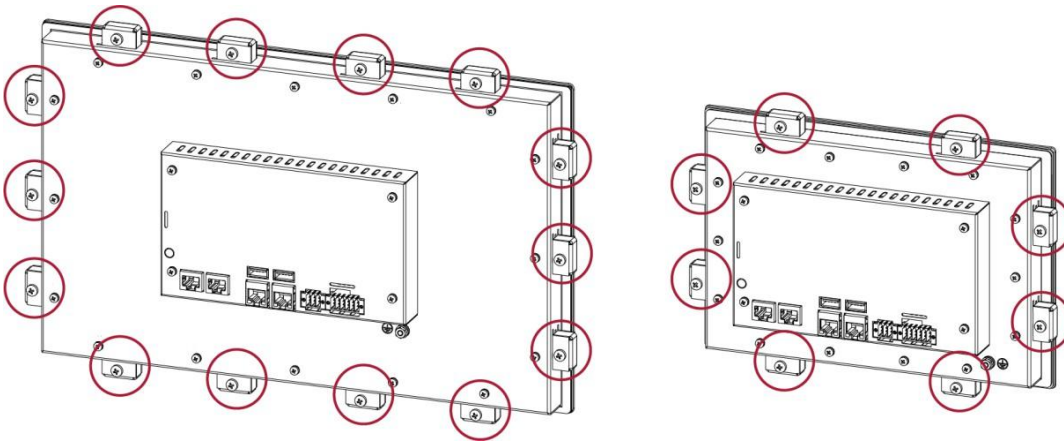

Fig. 1010: Fully tightening the securing clips

4. Insert the other securing clips and tighten the screws in all the securing clips equally (max 35 Ncm).
 - Astraada One Compact HMI Prime 15: 14 securing clips
 - Astraada One Compact HMI Prime 10: 8 securing clips
 - Astraada One Compact HMI Prime 7: 6 securing clips

5. Connection

WARNING

Uncontrolled and unpredictable operational behaviour!

Failure of certain components in electronic control systems may result in uncontrolled and unpredictable operational behaviour.

- ▶ All types of failure and the associated protection systems must be taken into account at system level.
- ▶ Comply with all automation system manufacturer instructions.

5.1. Power supply

The device is powered by an external 24 V DC power supply.

- ▶ Before plugging in the device, ensure that the external power supply meets the required specifications (type K to 61131-2).

External power supply (24 V DC)

Supply voltage	+24 V DC SELV (–15% / +20%)
Ripple current proportion	Max. 5 % The DC voltage level must not fall below 20.4 V.
Power consumption	Astraada One Compact HMI Prime 7: Total max. 0.6 A at +24 V DC (peak current 1.2 A) Astraada One Compact HMI Prime 10: Total max. 0.8 A at +24 V DC (peak current 1.5 A) Astraada One Compact HMI Prime 15: Total max. 0.9 A at +24 V DC (peak current 1.5 A)

Internal power supply

A power supply for the system electronics for an input voltage of 24 V DC (–15% / +20%) is integrated into the device. The power supply has integrated protection against reverse polarity and surge current protection (1.5 A).

Installation

- ▶ All connections and cables must be laid so as to prevent inductive and capacitive interference causing any damage to the device.
- ▶ Ensure that the infeed lines provide adequate current and voltage carrying capacity.

5.1.1. Connecting the power supply

CAUTION

Live parts!

- ▶ Before starting any work on the device, switch off all power feeds, including peripherals.

Astraada One Compact HMI Prime 7/10/15

- ▶ Connect the power supply to plug X1 according to the following table.

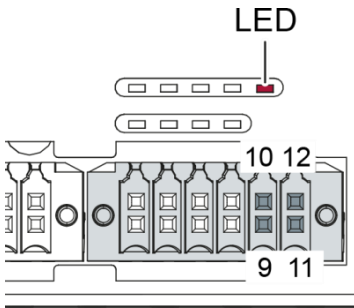

Fig. 1111: Power supply Astraada One Compact HMI Prime 7/10/15 connector X1 with power LED

Power supply plug X1		
Pin	Designation	Assignment
1...8	I/O	digital inputs and outputs (see "Digital inputs and outputs ")
9	L0+ 24 V	Power supply 24 V DC (–15 %/+20 %) (internal PLC) Astraada One Compact HMI Prime 7: max. 0.6 A (peak current 1.2 A) Astraada One Compact HMI Prime 10: max. 0.8 A (peak current 1.5 A) Astraada One Compact HMI Prime 15: max. 0.9 A (peak current 1.5 A)
10	L1+ 24 V I/O	Feed to digital output (max. 2 A for 0.5 A per output) for I/O
11	M0 / GND	–
12	L0+ 24 V	Power supply 24 V DC (–15 %/+20 %) (PLC internal processing) max. 1.5A Astraada One Compact HMI Prime 7: max. 0.6 A (peak current 1.2 A) Astraada One Compact HMI Prime 10: max. 0.8 A (peak current 1.5 A) Astraada One Compact HMI Prime 15: max. 0.9 A (peak current 1.5 A)

The following counterparts have been tested with the S2C-SMT 3.5 (Weidmüller) connector and are approved for use with the device:

- ➔ B2CF 3.50/12/180

NOTE

High-frequency sources of interference can affect the function

- ▶ It is strongly recommended to install the supplied ferrite sleeves on the digital output wires (Pins 1,3,5,7) and Pin 10, (if separately supplied) over two turns. (Except Astraada One Compact HMI Prime 7)



Fig. 1212: Ferrite sleeve and cable

5.2. Data connections

5.2.1. Block circuit diagram Astraada One Compact HMI Prime 7/10/15

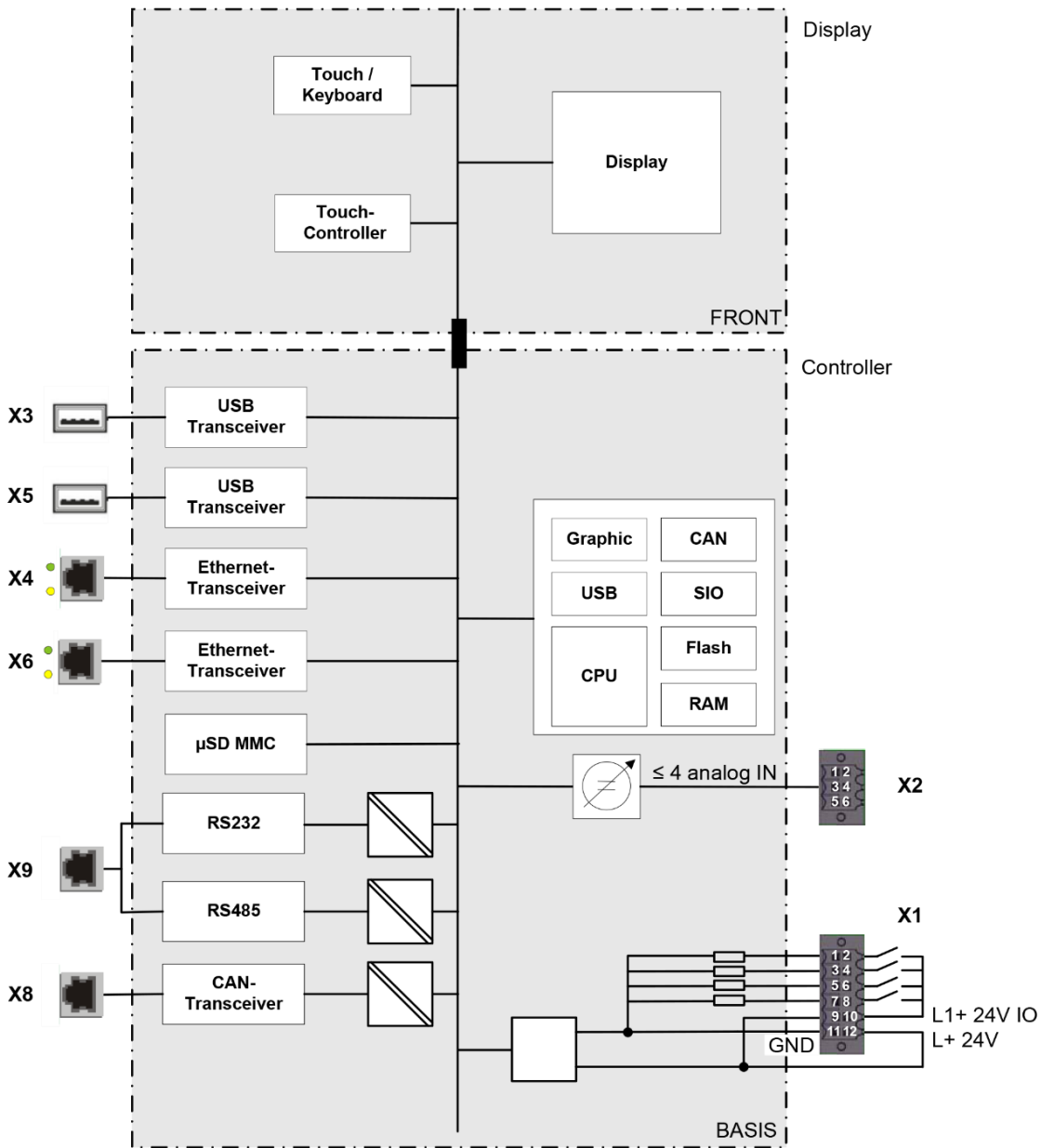

Fig. 1313: Block circuit diagram Astraada One Compact HMI Prime 7/10/15

5.2.2. Digital inputs and outputs

The digital outputs are positive switching 24 V outputs with an output current of max. 500 mA (per channel). They have a common reference potential (GND) with the supply voltage.

NOTE

Damage to the inputs or to the device!

Voltages over ± 32 V can damage the inputs or the device.

- ▶ No voltage in excess of ± 32 V may be present at the inputs.

The digital inputs are type 1 or 3 (IEC 61131-2) positive switching inputs of type 1 or 3 (IEC 61131-2). They are designed for nominal input voltages of 24 V. The input signals are transmitted internally on a cyclical basis for process data processing. An open input is interpreted as static 0. The inputs also have a common reference potential (GND).

The following counterparts have been tested with the S2C-SMT 3.5 (Weidmüller) connector and are approved for use with the device:

- B2CF 3.50/12/180F

This only concerns Astraada One Compact HMI Prime 10 and Astraada One Compact HMI Prime 15:

Digital inputs and outputs, plug X1					
Pin	Designation	Assignment	Pin	Designation	Assignment
1	DO 1	digital output	6	DI 3 / C3	digital input / counting input 3
2	DI 1 / C1	digital input / counting input 1	7	DO 4	digital output
3	DO 2	digital output	8	DI 4 / C4	digital input / counting input 4
4	DI 2 / C2	digital input / counting input 2	9...1 2	–	Power supply (see "Power supply" section)
5	DO 3	digital output			

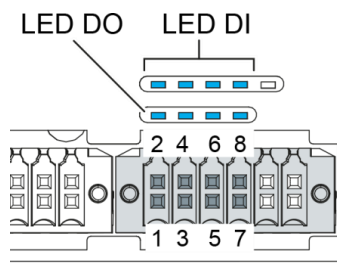

Fig. 1414: Digital inputs and outputs Astraada One Compact HMI Prime plug connector X1 with LEDs 1 to 8

NOTE

High-frequency sources of interference can affect the function.

- ▶ It is strongly recommended to install the supplied ferrite sleeves on the digital output wires (Pins 1,3,5,7) and Pin 10, (if separately supplied) over two turns. (Except Astraada One Compact HMI Prime 7)



Fig. 1515: Ferrite sleeve and cable

Data from the digital outputs

Feature	Value	Description
Output type	semiconductor	Non-storing, current supplying (positive switching)
Protective circuit for inductive loads	41 V terminal voltage (typ.) compared to +24 V	fast de-excitation (must be provided externally)
Status display	yes	one orange LED per output Lights up at logical 1
Overload protection	yes	In the case of thermal overload, auto-resetting
Short circuit protection response threshold	yes	electronic voltage limitation: typ. 7 A The current is limited electronically. Activation of short circuit protection results in thermal overload and tripping of thermal overload protection. Permissible limits based on cold state: max. 10,000 short circuits; overall duration max. 500 hours.
Status under unclear operating conditions	Logical 0	If the supply voltage is insufficient, and at booting up and shutting down the control system, the outputs are set to logical 0.
Output delay "0" after "1"	typ. 1 ms	–
Output delay "1" after "0"	typ. 1 ms	–
Output capacitance	< 20 nF	–
Rated voltage	+24 V DC	–
Voltage drop (at rated current)	< 0.1 V	–
Rated current at "1" signal	0.5 A	–
Total current of all outputs	max. 2 A	–

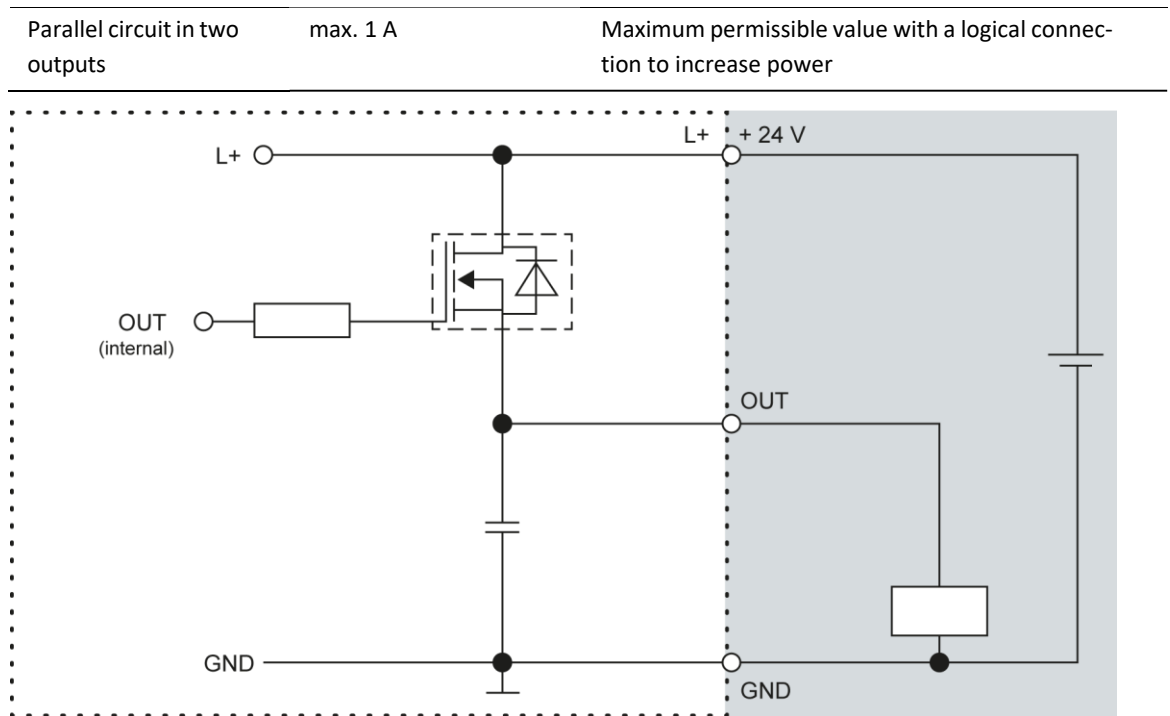

Fig. 1616: Circuit diagram of the principles of positive switching output

Data from the digital inputs		
Feature	Value	Description
Type of inputs	Type 1, 3	To IEC 61131-2 Draws current (positive-switching)
Cable length	max. 30 m	For unshielded connection cables Cables over 30 m in length must be shielded.
Cable cross-section within the control cabinet	0.14 – 1.5 mm ² (26-16 AWG)	Aim for plug connector limits to UL specifications.
Field wiring	according to regulations and standards	Comply with all local regulations and the stipulations of DIN EN 61131-2.
Rated load voltage	24 V DC (SELV)	–
Delay time	1 ms	Applies for transitions from 0 to 1 and 1 to 0
Signal evaluation	cyclical	Dependent on the cycle time set in the programming system
Protection against reverse polarity	yes	–
Potential isolation	No	–
Status display	Yes	One yellow LED per input Lights up at logical 1

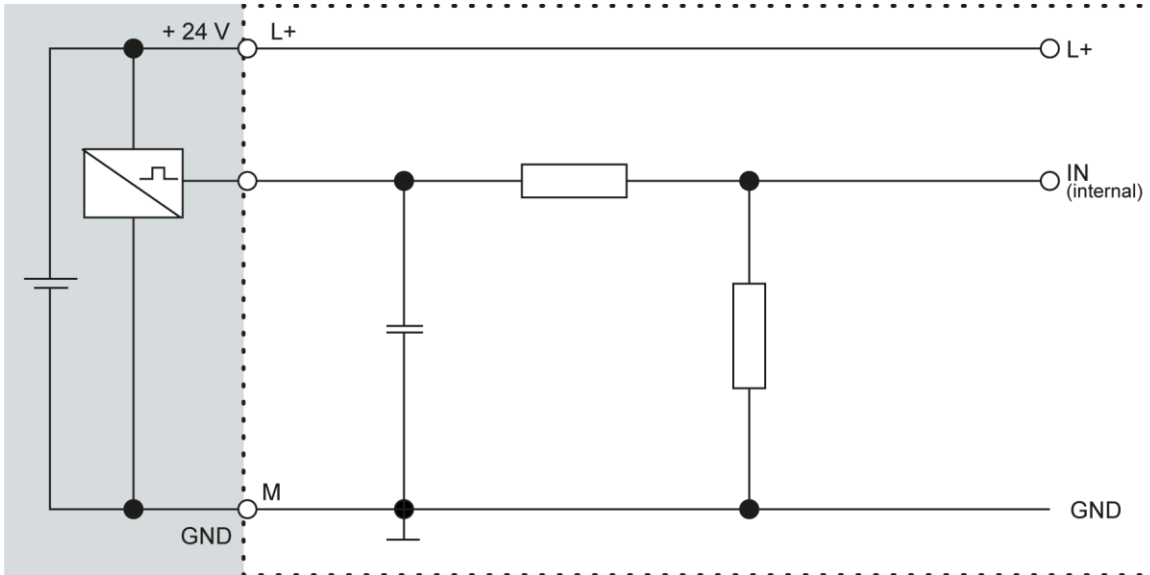

Fig. 1717: Circuit diagram of the principles of positive switching input

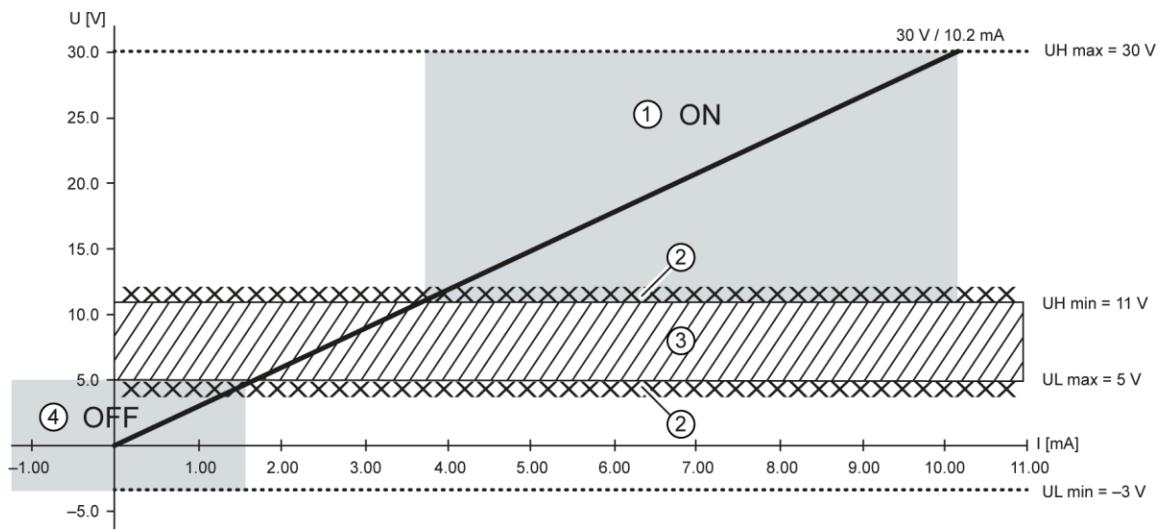

Fig. 1818: Operating ranges of the digital inputs (type 1/3), negative switching

Item	Assignment	Item	Assignment
1	"ON" range	3	Transition range
2	Signal-noise ratio <1 V	4	"OFF" range

5.2.3. Counter inputs (C)

The 4 digital inputs can also be used to connect an encoder or count pulses (inputs C1...C4). This function must be enabled by appropriate licensing (obtainable also retrospectively).

The counting inputs C1...C4 have quick filters, the unipolar inputs I5...I16 have a hysteresis. The counting inputs are linked to the signals of the other unipolar inputs. There is no changeover.

Available configurations of the counting inputs:

- ➔ Up/Down counter
- ➔ Pulse/Direction counter
- ➔ Quadrature decoder

One of the counting inputs can also be used as a capture input. This configuration requires 3 of the inputs (partially as a CNT input or CAPT input). The flanks for Up, Down or Pulse can be defined as rising and/or falling flanks.

Direction: High = Up; Low = Down

Examples for counters: Up/Down; Pulse/Direction; Encoder (A/B)

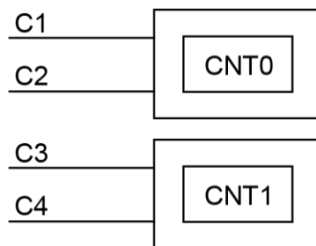

Fig. 1919: Counter Up/Down or Pulse/Direction

Pin	Assignment	Pin	Assignment
C1	Up, Pulse, A (CNT0)	C3	Up, Pulse, A (CNT1)
C2	Down, Direction, B (CNT0)	C4	Down, Direction, B (CNT1)

Example for a counter: Capture input or counter input

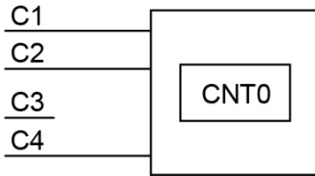

Fig. 2020: Counter with Capture input

Pin	Assignment	Pin	Assignment
C1	Up, A (CNT0)	C3	–
C2	Down, B (CNT0)	C4	Capture (rise), Z (CNT0)

The counter CNT1 is not available with this configuration.

Data for the counting inputs

Counting inputs		
Function	Value	Description
Number of counters	2	–
Signal voltage	(1): DC 15...28 V (0): DC –3...3 V	Pulse width within the valid level for at least 1 μ s
Max. frequency: Signal Counter	500 kHz 1 counts/ μ s	Special installation instructions are applicable to frequencies over 100 kHz. At the maximum counting frequency, the signal generator must ensure a flank steepness of at least 20 V/ μ s.
Min. Pulse width	1 μ s	Per level
counter resolution	32 bit	–
Internal pull-up	3 k Ω	–

Installation instructions

- ➔ Screened cable must be used to connect the counters.
- ➔ The power supply to the sensor (24 V DC; GND) and the signal must both be within the same cable.
- ➔ The PLC and sensor must be supplied by the same power supply unit.

5.2.4. Analogue inputs (only S02 – S05)

Basic considerations for analogue inputs

- ➔ An analogue input channel always consists of two connections: AI (U) or AI (U/T) and AGND.
- ➔ The AI (U/T) channels can either measure voltages (U) or evaluate PT100(0) sensors.
- ➔ The AI (U) channels can measure voltages or be used for compensation of the line resistances for PT100(0) measurements (3-wire measurement).
- ➔ The Earth/Ground/GND lead of a voltage sensor or temperature sensor connected to an analogue input may be connected only to AGND (not to GND or PE (equipotential)).
- ➔ Different AGNDs (such as on a terminal strip) may not be connected together.
- ➔ AGNDs may not be connected to the general GND of the control panel or to the "M" on the control unit (GND and AGND are already connected within the control unit, via a special filter).
- ➔ AGNDs may not be connected directly to the equipotential bonding conductor (PE) of the machine or system.
- ➔ Long cables and wires with a small cross-section lead to voltage drops and deviations in PT100(0) measurements (due to resistance of the lead). These unavoidable deviations must be taken into account when planning the wiring.
- ➔ To avoid interference, analogue I/O wires must be kept separate from digital signals and power cables.
- ➔ Screened cables are advisable for all analogue I/Os. The screen is maintained from the respective sensor or instrument through into the control panel or close to the control unit.

The following counterparts have been tested with the S2C-SMT 3.5 (Weidmüller) connector and are approved for use with the device:

Weidmüller B2CF 3.50/06/180(F) SN BK

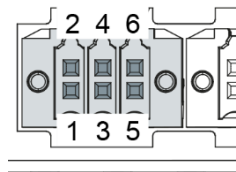

Fig. 2121: Analogue inputs on X2

Analogue inputs X2			
Pin	Assignment	Pin	Assignment
1	AI1 (U/T)	2	AI3 (U/T)
3	AGND	4	AGND
5	AI2 (U)	6	AI4 (U)

Data from analogue inputs

Data from analogue inputs		
Feature	Value	Description
Cable length	max. 30 m	Only valid for unshielded connection cables. Cables over 30 m in length must be shielded.
Modulation method	Delta-sigma modulation	–
Shared points between the channels	AGND reference ground	–
Clamp arrangement	Shielding on common AGND pins	–
Sampling duration/rate for measuring values	1 ms	A reading is taken from each input channel every millisecond, regardless of how many channels are actually in operation.
Sampling rate Operating mode AI-PT	250 ms	In operating mode AI-PT, calculations are carried out after the millisecond sampling rate. A new value is available in the user program every 250 ms.

Digital filtering		
Available filter settings	Time range for averaging	Time range for averaging Operating mode AI-PT
0	1 ms	0.25 s
10	10 ms	2.5 s
100	100 ms	25 s
1000	1,000 ms (1 s)	250 s

If filtering is active, an average is calculated for the set time range. However, a value is still issued during the sampling rate interval. For example, if the filter is set to 1,000, the average of the measurements for the previous 1,000 ms / 1,000 measurements is issued each millisecond (or, in the case of operating mode AI-PT, the average for the last 250 ms / 1,000 measurements).

The filtering can be activated and configured using CODESYS V3. The sampling rate is constant. It can only be filtered with a whole multiple of the sampling rate.

Operating modes for the analogue inputs

NOTE

Damage to channel!

High voltages can damage analogue channels, stopping them from working correctly.

- ▶ Ensure the input voltage does not exceed ± 30 V.

Operating mode: voltage input AI (U)

Feature	Value	Description
Connections per input	–	AI (U/T) and AGND or AI (U) and AGND; connect screen to AGND.
Measuring range	–10 to +10 V	–
Input impedance in signal range	100 k Ω	between AI (U/T) and AGND or between AI (U) and AGND Value is valid whether the channel is switched on or off
Max. error at 25 °C	± 0.25 % (± 50 mV)	–
Temperature coefficient	± 40 ppm/K (± 0.4 mV/K)	–
Digital resolution	24 bit	–
Data format in user program	32 bit real	(floating-point number) in millivolts (mV)
Maximum permissible permanent overload	Max. ± 30 V compared to AGND	± 30 V = max. voltage at AI channel
Value of least significant bit	1.2 μ V	–
Output of digital value in case of overload	–	If a voltage of ± 10 V is applied to an AI (U), a plausible value is still given up to approx. ± 15 V. The specified accuracy is only valid for the range –10 to +10 V. If the voltages applied are greater than +15 V or less than –15 V, an error bit (FAULTN/FAULTP) is set in the process image, which can be read by the user program.
Input type	–	Unsymmetrical voltage metering (single-ended)
Reference potential	AGND	–
Dynamic characteristics		
Analogue filtering	Second-order low pass, limit frequency 650 Hz	–

Operating mode: voltage input AI (U)

Feature	Value	Description
Greatest temporary deviation during electrical error testing according to IEC 61131-2	1% of measuring range	–

Operating mode: temperature inputs AI-PT

Feature	Value	Description
Connections per input	–	Sensor connection between AI (U/T) and AGND (if necessary a further AI (U) channel can be used for 3-wire measurement)
Possible sensors	PT100 and PT1000 acc. to EN 60751	Platinum sensors of accuracy classes AA, A, B and C may be used
Measuring range	–40 to +200 °C	–
Measuring current (RMS)	0.3 mA	–
Conversion time	250 ms	–
Max. error at 25 °C	±2100 ppm (±0.5 °C)	–
Temperature coefficient	±50 ppm/K (±0.012 °C/K)	–
Digital resolution	24 bit	–
Data format in user program	2 × 32 bit real	(floating-point number) in Ohms (Ω) and degrees Celsius (°C)
Linearisation	–	The value in degrees Celsius is calculated from the resistance value and linearised (6th degree polynomial)
Input type	–	2-wire measurement or 3-wire measurement
Reference potential	AGND	–

Dynamic characteristics

Analogue filtering	Second-order low pass, limit frequency 650 Hz	–
Greatest temporary deviation during electrical error testing according to IEC 61131-2	1% of measuring range	–



Voltage input AI (U)

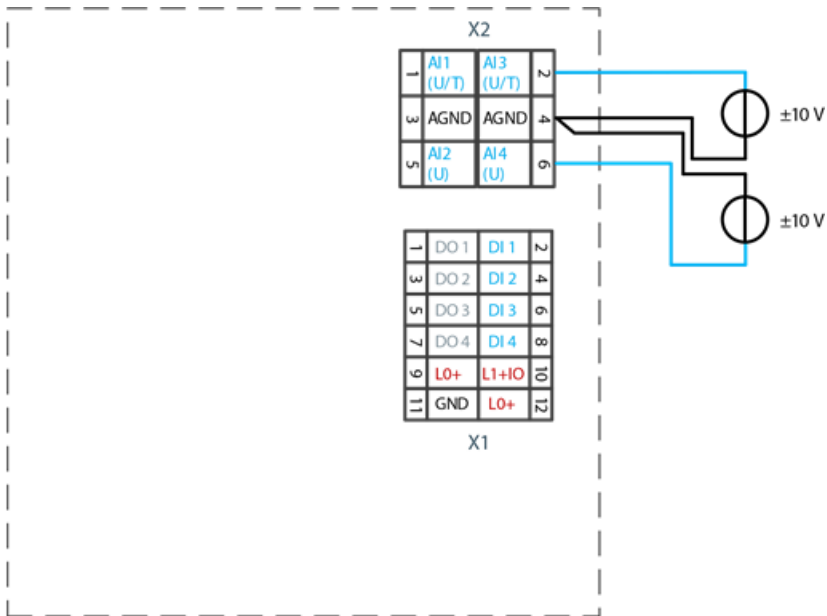

Fig. 2222: Example connection: voltage input

- ▶ Only use the corresponding AGND for each voltage input.
- ▶ Do not connect AGNDs from different channels.
- ▶ AGNDs from different channels must always be connected separately to the plug X1.
- ▶ Do not connect to the common GND. The required connections can already be found on the circuit board.
- ▶ Cables to the analogue sensors/encoders should be connected as directly as possible (avoid the use of terminals and terminal blocks).

Temperature measurement AI (T)

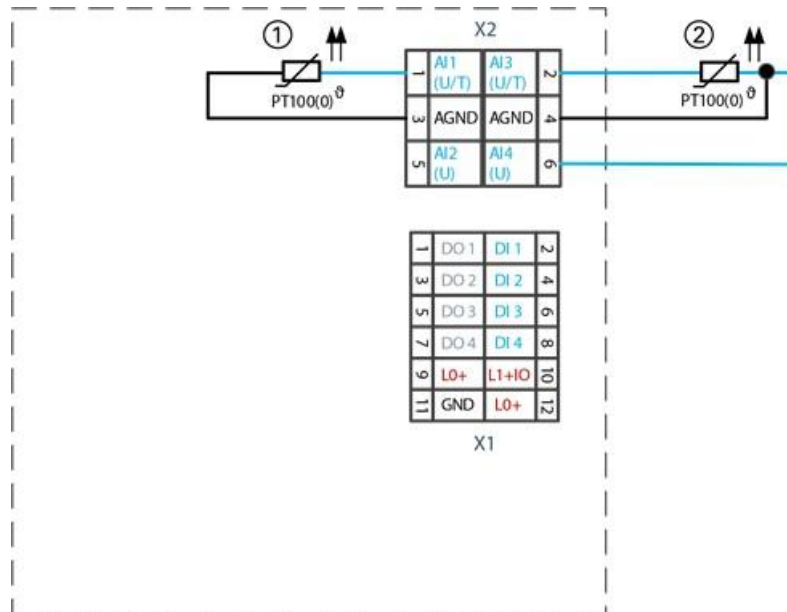

Fig. 2323: Example connection: temperature measurement

Item	Description
1	PT 100 with 2-wire connection
2	PT 100 with 3-wire connection

- ▶ Only use the corresponding AGND for each input.
- ▶ Do not connect AGNDs from different channels.
- ▶ Do not connect to the common GND. The required connections can already be found on the circuit board.
- ▶ Cables to the PT100(0) sensors should be connected as directly as possible (avoid the use of terminals and terminal blocks).
- ▶ Only connect PT100(0) sensors to AI (U/T) channels.

2-wire measurement

Resistance can result in a measurement error, which in the case of long cables with a small cross-section can be up to 10°. If the temperature of the sensor is known, this deviation can be subtracted by the software automatically and compensated (alternatively, use 3-wire measurement).

3-wire measurement

The nearest AI (U) connection is used to compensate the resistance in the cable. It can only be used directly in conjunction with the following AI (U/T) channel. Channels 1 and 2, and also channels 3 and 4 each form a pair for 3-wire measurement.

5.2.5. Ethernet interface

The on-board Ethernet adapter has one 10/100-Base-T RJ-45 port for connection to the network.

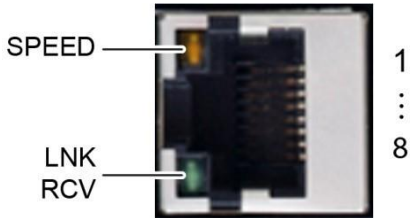

Fig. 2424: Ethernet interface X4

Assignment of Ethernet interface plug X4			
Pin	Assignment	Pin	Assignment
1	TX+	5	NC
2	TX-	6	RX-
3	RX+	7	NC
4	NC	8	NC

LEDs		
LED	Colour	Meaning to IEEE 802.3 clause 25
LNK/RCV	green	Link, Data Receive Flashing: connection active; data transfer in progress Off: no connection established
SPEED	yellow	On = 100 Mbit/s Off = 10 Mbit/s

5.2.6. EtherCAT interface

The onboard Ethernet adapter has two RJ-45 10/100 Base-T interfaces for networking. The Ethernet interface **X6** can be used as the EtherCAT master.

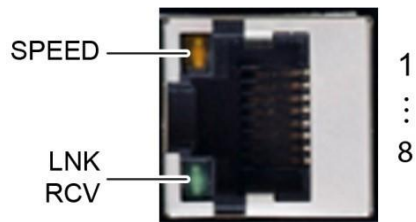

Fig. 2525: Ethernet/EtherCAT interface X6

Assignment of Ethernet/EtherCAT interface connector X6			
Pin	Assignment	Pin	Assignment
1	TX+	5	NC
2	TX-	6	RX-
3	RX+	7	NC
4	NC	8	NC

LEDs		
LED	Colour	Meaning to IEEE 802.3 clause 25
LNK/RCV	green	Link, Data Receive Flashing: connection active; data transfer in progress Off: no connection established
SPEED	yellow	On = 100 Mbit/s Off = 10 Mbit/s

5.2.7. USB interface

Devices with a USB interface can be connected to the USB host port (Rev. 2.0). Suitable USB device classes are: USB stick, keyboard or USB-Serial adapter



B1
:
B4

Fig. 2626: USB interfaces X3 and X5

Assignment of USB interface connectors X3 and X5

Pin	Assignment	Pin	Assignment
B1	VCC	B3	D+
B2	D-	B4	GND

NOTE

Damage to USB stick and malfunction due to data loss!

Removing a USB stick while it is still in use and data are being transferred can render the USB stick unusable. Open files which can no longer be accessed because the USB stick has been removed can block the device.

- ▶ Therefore ensure that all operations are complete before removing the USB stick.

NOTE

Damage to property and malfunctions due to data loss!

The USB interface is protected against overloading (> 0.5 A). In the event of a short circuit during operation, the control unit may trigger a reset of the system.

Substantial property damage and damage to the USB device may ensue.

- ▶ Before using a USB device, check carefully its power requirements.

NOTE

Failures and malfunctions will occur if direct connections are made to signal earth!

- ▶ Use only USB devices that have no direct connection between signal earth and the housing.



The USB interface plug is designed to withstand 1,000 plugging and unplugging cycles.

5.2.8. CAN interface (only S03 – S05)

Properties of the CAN interface	
Standard	ISO 11898
Maximum Baud rate	1 MBit/s
Lowest adjustable Baud rate	50 kBit/s
Contacts	Electrically isolated
Assignment	to CiA303

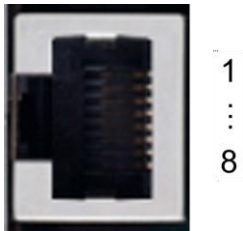

Fig. 2727: CAN interface X8 (X12)

Assignment of CAN interface connector X8 (X12)			
Pin	Assignment	Pin	Assignment
1	CAN_H	5	NC
2	CAN_L	6	NC
3	ISO GND	7	ISO GND
4	NC	8	NC

If the CAN interface is located at the start or end of the CAN bus topology:

- ▶ set switch S2 to ON in order to switch on the 120 Ω terminal resistance between CAN_L and CAN_H.

5.2.9. Serial interfaces (only S04 – S05)

The module has two serial communications interfaces (1x RS-232 and 1x RS-485), which are connected via the common RJ45 plug X6.

Maximum baud rate for both interfaces: 115 kBd

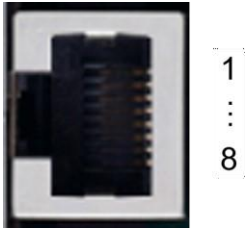

Fig. 2828: RS-232 / RS-485 interface X9

Pin assignment for RS-232 / RS-485 interface connector X9			
Pin	Assignment / software interface	Pin	Assignment / software interface
1	RS-232 RX / COM 1	5	RS-485 Tx/Rx- / COM 2
2	RS-232 TX / COM 1	6	NC
3	NC	7	(reserved)
4	RS-485 Tx/Rx+ / COM 2	8	ISO GND

The RS-485 interface is “soft” terminated in the dialogue controller with 680 Ω.

If the interface is located at the start or end of the bus topology:

- Set switch S3 to ON in order to switch on the 120 Ω differential terminating resistor.

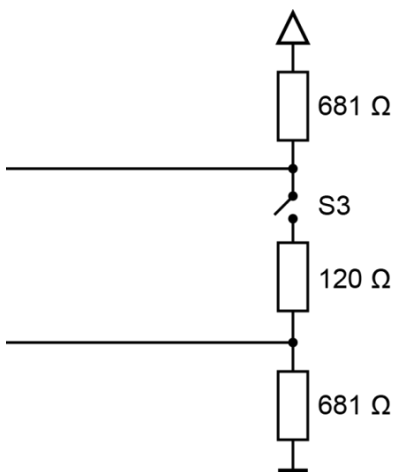

Fig. 2929: RS-485 switchable terminating resistor



As far as possible, the assignment of the interfaces should be carried out in accordance with the specifications given in "MODBUS over Serial Line; Specification and Implementation Guide V1.02".

Signal interference and terminating resistor

To minimise interference, the following instructions must be complied with.

Actively driven bus

- ➔ An appropriate protocol must be employed to ensure that at all times one of the bus participants is actively driving the bus.
- ➔ For a highly symmetrical signal-noise ratio the bus must have defined statuses for logical "1" ($A-B < -0.2\text{ V}$) and logical "0" ($A-B > +0.2\text{ V}$).

Undriven bus

- ➔ The bus termination must be as asymmetric as possible to ensure the greatest possible signal-noise ratio (to reduce the symmetrical signal-noise ratio).
- ➔ In order to achieve the necessary voltage difference between the signals, a suitable resistor network must be used as the line termination.
- ➔ The necessary size of the resistors is governed by the bus length and transmission rate (similarly to the line termination for Profibus, see DIN EN 61158-2).

Connections with GND

To minimise common-mode interference or malfunctions due to potential differences:

- ▶ Check the topology and line lengths to determine whether additional connection to GND are necessary.
- ▶ For electrically isolated interfaces with connections to the reference ground at one point: link to GND.
- ▶ Where necessary, provide an attenuated link to GND (for instance via $200\ \Omega$) at multiple points.

6. Operation

6.1. Switching on and off

NOTE

Damage or malfunction!

- ▶ Do not insert, connect, undo or touch any connections whilst the device is in operation.
- ▶ Before starting any work on the device, switch off all power feeds, including those to any connected peripherals (sensors and programmable devices etc. with independent power supplies).

NOTE

Damage to property!

- ▶ Before connecting the power supply, ensure that all cabling and the polarity of all the connections are correct.

Switching on

The device does not have an on/off switch. The device starts automatically when the system is switched on or the power is connected.

Switching off

The device is switched off when the system is switched off or the power supply is disconnected.

6.2. Initial Setup of the device

6.2.1. Web Terminal Configuration

The device must be connected to the network with the correct settings before it can be used.

NOTE

Damage to property!

- ▶ Before connecting the power supply, ensure that all cabling and the polarity of all the connections are correct.

1. Supply the device with power (24 V).
After the start the current IP address and network mask of the device are shown at the top right of the display.
2. Connect the device to a programming computer using a network cable (X4) and network switch.
3. Open a web browser on the programming computer.
4. Enter the IP address of the device into the web browser.

The login screen will appear.

User Login:

Name:

Password:

Fig. 3030: Login window

5. Name: admin

The default password, which is printed on the device label, serves as the password.

NOTE

Devices without a password on the device label

If your device does not have a password printed on the device label, the username and password are the same.

e.g. User: admin / Password: admin.

The web configuration page will be displayed:

Configuration

[Network](#)
[Real-Time-Clock](#)
[Display](#)
[FTP-Server](#)
[Users](#)

System

[Info](#)
[Update](#)
[Reboot](#)
Format Filesys

PLC-Manager

[Control](#)
[Application Info](#)
[Application Files](#)
[Font Files](#)

Fig. 3131: List of web interface settings

6. Click on the "Network" link

The Network Configuration page is displayed.

Network Configuration

COMMON

Hostname
Default Gateway
DNS Server 1
DNS Server 2

ETH0

Mode:
IPAdress
NetMask

ETH1

Mode:

Fig. 3232: Network Configuration page

7. Check the network settings and if desired make changes in the respective text boxes.
Configuration DC211x: ETH0 = X4, ETH1 = X5
8. Save the settings by clicking on "Save".
9. Additional settings can also be viewed and/or modified on the web configuration page (for example "system time", display resolution, TargetVisu).

10. In order to activate the modified settings, reboot the device:
 Disconnect the device temporarily from the power supply.
 – or –
 Click on "Reboot" in the web interface and then confirm it on the next screen by clicking on "Reboot Module".

The device is now configured and ready for use.

6.2.2. On-Screen Configuration

NOTE

Damage to property!

- ▶ Before connecting the power supply, ensure that all cabling and the polarity of all the connections are correct.

1. Supply the device with power (24 V). After the start the current IP address and network mask of the device are shown at the top right of the display.

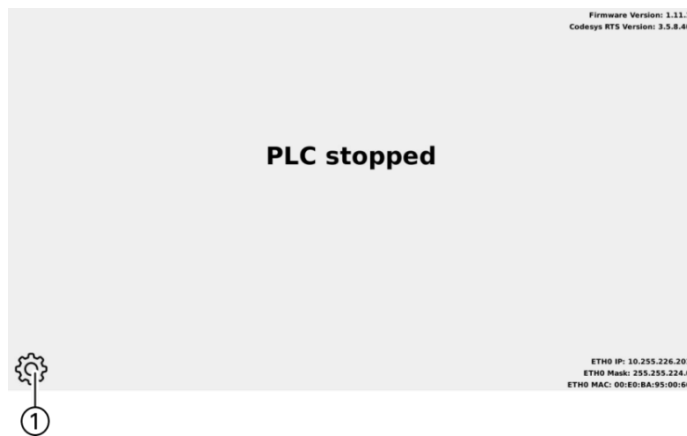

Fig. 3333: Main screen of the device

2. To change the IP address via the display, press the "Settings" icon (1). The page with the network settings of the device appears.

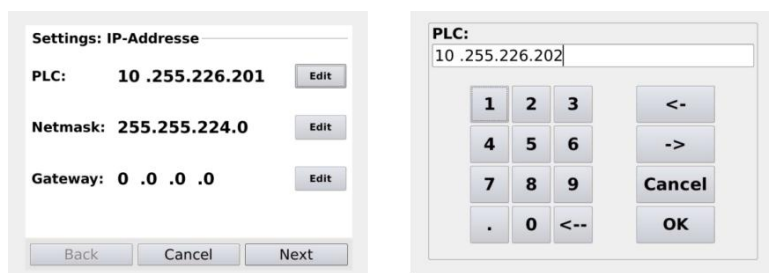

Fig. 3434: Network settings

-
3. If necessary, press the "Edit" button and change the network settings as required (IP address, network mask, gateway).
 4. Press the "Next" button.
The page with the summary of the network settings appears.

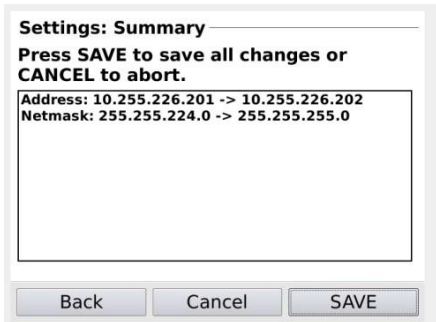

Fig. 3535: Summary of the network settings

5. To change other settings or to correct the changes, press the "Back" button.
6. If no settings were changed, press the "OK" button.
The main screen of the device will be displayed.

– or –

Press the "Save" button.

The settings will be saved and the device will restart automatically.
The device is now configured and ready for use.

6.2.3. Status indicators

The status display function is dependent on the software development environment used in conjunction with the device.

The operating status LEDs show the current status of the power supply, the module mode and any error messages.

Location of the status LEDs

The Run/Stop and Error LEDs display the system status.

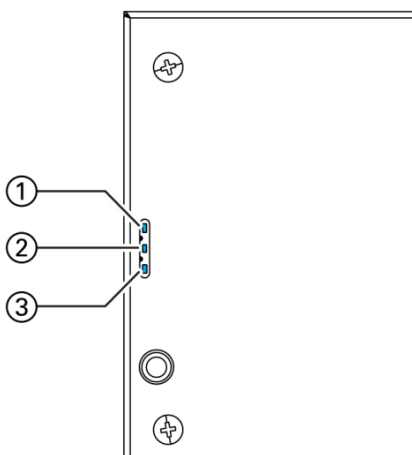

Fig. 3636: Location of the status LEDs

LED		description
1	Power (green)	shows that the power supply to the electronics is correct.
2	Run/Stop (yel- low/green/red)	shows the system statuses.
3	Error (red)	shows the device has been stopped due to an error.

Meaning of the LEDs

System statuses are shown using flashing signals on the Run/Stop LED in yellow.

While the Run/Stop light is flashing yellow: the device is in use and must not be switched off.

The device does not show warnings via the LEDs during start-up.

6.2.4. Function key S1

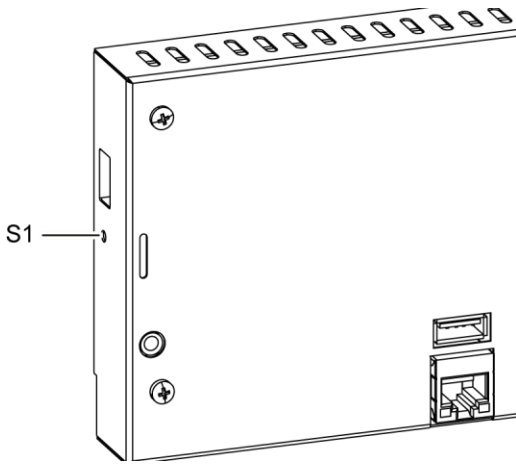

Fig. 3737: Function key (S1)

Function key (S1)		
Operating status	Action	Command
Boot phase	Press.	Change to maintenance mode
CODESYS PLC/ CP1131-P	Press briefly.	Toggle between PLC run and stop mode
	Press and hold.	Stop the PLC with resetting of variables (cold reset)

6.2.5. Real Time Clock

Setting the date and time

The time can be set and read via the web configuration page or via the CODESYS V3 library.

Changing the battery

The battery is not designed to be changed by the user; the manufacturer should be contacted in order to change the battery.



For the battery the regulations according to UN 3091 -PI 970 Section II Button Cell apply.

Further PSDS/MSDS information from the manufacturer is applicable batteries/rechargeable batteries as specified in UN 3091 -PI 970 Section II Button Cell.

6.2.6. microSD card (only S03 – S05)

WARNING

Serious injury as a result of uncontrolled and unpredictable operational behaviour!

Inserting or removing the microSD card can result in the device malfunctioning. Failure in electronic control systems may result in uncontrolled and unpredictable operational behaviour.

- ▶ Insert or remove a microSD card only when the device is switched off.

NOTE

Loss of data!

microSD cards do not have their own write protection system.

- ▶ Ensure that no data is deleted or overwritten by accident.

Inserting a microSD card

1. Switch the device off.
2. Insert the microSD card into the microSD card slot.
3. Switch the device on again.

The microSD card is now ready for data transfer (read, write and copy).

Path: /media/sd



Max. possible storage capacity: 32 GB.

The life cycle of the gold-plated contacts is up to 10,000 plugging and unplugging cycles.

The microSD card drive has a push-in/push-out insertion and ejection mechanism.

To avoid malfunctions, do not withdraw the microSD card by pulling it.

6.3. Troubleshooting

6.3.1. No network connection

- ▶ Check the cabling / switch.
- ▶ Check whether an IP address has been duplicated.
- ▶ Check the network settings on the PC: The subnet and the subnet mask settings must be the same as those for the controller.
- ▶ Check the firewall / anti-virus programs on the PC.
- ▶ Check the Lifeguard settings.

6.3.2. CODESYS application is in Error Stop

1. Log in to the device via a web browser.
2. Determine the cause of the fault (Diagnostics > PLC Log/System Log).
3. Correct the fault.
4. Restart the device.

The device is now ready for use.

7. Maintenance and service

Repairs and corrective maintenance may be carried out only by the manufacturer or authorised customer service centres.

7.1. Maintenance

WARNING

Uncontrolled and unpredictable operational behaviour!

Failures or malfunctions may result in uncontrolled and unpredictable operational behaviour.

- ▶ Do not insert, connect, undo or touch any connections whilst the device is in operation.
- ▶ Before starting any work on the device, switch off all power feeds, including those to any connected peripherals (sensors and programmable devices etc. with independent power supplies).

If the device is used correctly it should not require maintenance.

- ▶ Make sure all the ventilation holes are kept free of obstructions.
- ▶ Do not open the device. Contact the customer service if work is required on the device.

7.2. Cleaning

NOTE

Damage to the front panel!

The front panel is of glass and must not be exposed to any mechanical or chemical stress.

- ▶ Do not use any high-pressure cleaners or steam jets.
 - ▶ Do not use any corrosive cleaning products, any thinners, any abrasive media or any hard objects.
 - ▶ Do not apply any undue force to the front face. Do not bend the device.
 - ▶ Do not place any heavy, hard or sharp-edged objects on the device.
 - ▶ Do not dismantle the devices.
-
- ▶ To avoid faults due to inadvertent activation, switch the device off before cleaning the front panel.
 - ▶ Clean the surfaces using only a dry, lint-free cloth.
 - ▶ Clean the glass only with normal window-cleaning agents or alcohol solutions.

8. Uninstallation

1. Disconnect the device and its peripherals from the power supply.
2. Unplug all plug connectors and cables.

NOTE

Damage to the device!

If uninstallation is performed carelessly the device can fall out of the installation cut-out or be damaged.

- ▶ Do not tilt the device.
- ▶ Secure the device against falling, especially when taking it out of the installation cut-out.

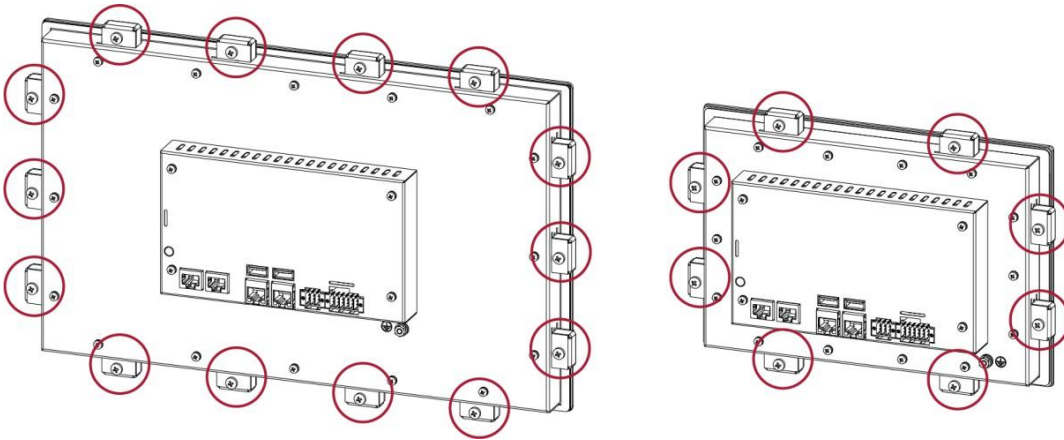

Fig. 3838: Undoing the screws

1. Undo the screws on all the securing clips equally.
DC Prime 15 : 14 securing clips
DC Prime 10: 8 securing clips
DC Prime 7: 6 securing clips

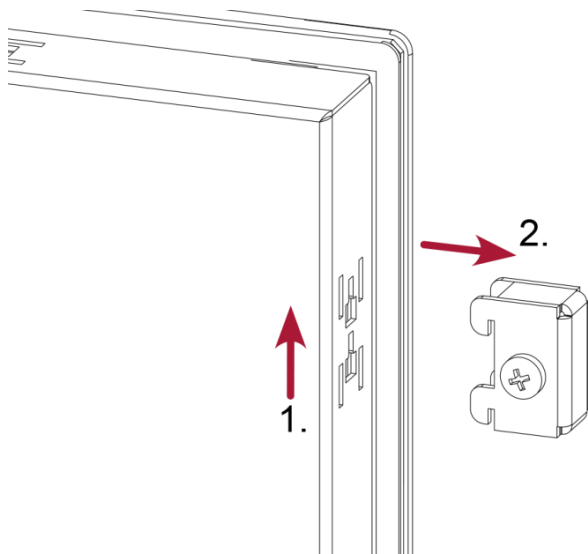

Fig. 3939: Removing the securing clips

1. Removing the securing clips.

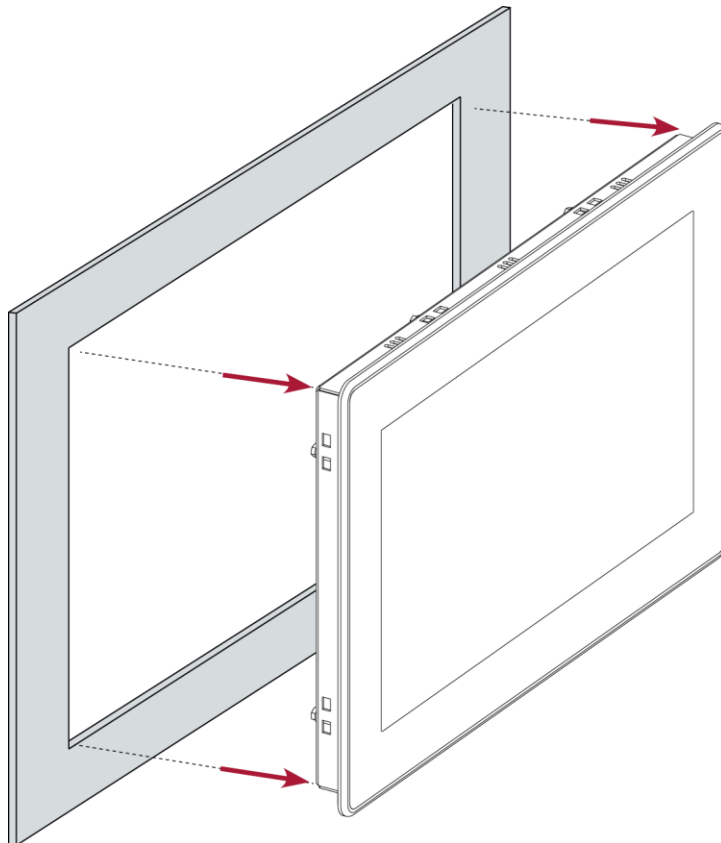

Fig. 4040: Pushing the device out of the installation cut-out

2. Push the device evenly forward out of the installation cut-out.

9. Disposal

The device contains the following components which need to be disposed of separately:

- ➔ Metals
- ➔ Electronic components
- ➔ Battery

The respective national regulations for disposal of electrical devices in B2B trade are applicable.

The following options are available for disposal of the device:

Disposal by the manufacturer

Unless agreed otherwise, devices can be sent back for disposal.

Disposal in accordance with regional regulations

- ▶ Dismantle the device and disassemble it completely into its component parts.
- ▶ Send the metal parts for metal recycling.
- ▶ Sort the electronic parts (circuit boards, drives etc.).
- ▶ Dispose of the electronic scrap in accordance with the national laws and regulations.
- ▶ Check that the battery is fully discharged.
- ▶ Dispose of the battery in accordance with the national laws and regulations, via an authorised collection point.

10. Information and options

Dialog Controller	Compact HMI Prime 7	Compact HMI Prime 10	Astraada One Compact HMI Prime 15
Order no. <i>(Single Core)</i>	S-01010104-0104 S-01010104-0204 S-01010104-0304 S-01010104-0404 S-01010104-0504	S-01010104-0105 S-01010104-0205 S-01010104-0305 S-01010104-0405 S-01010104-0505	S-01010104-0108 S-01010104-0208 S-01010104-0308 S-01010104-0408 S-01010104-0508
<i>(Dual Core)</i>	S-01010104-2404 S-01010104-2504	S-01010104-2405 S-01010104-2505	S-01010104-2408 S-01010104-2508
Display Diagonal size	7"	10,1"	15,6"
Resolution	800 x 480 Pixel	1280 x 800 Pixel	1920 x 1080 Pixel
Colours	TFT: 16,7 M		
Brightness	360 – 475 cd/m ³	400 – 475 cd/m ³	400 – 500 cd/m ³
CPU, User memory			
CPU	800 MHz ARM [®] with Cortex™-A9 Single Core or Dual Core		
Program memory (flash)	512 MB (max. 2048 MB) 2 GB <i>(Dual Core)</i>		
Program memory and data memory (RAM)	512 MB <i>(Single Core)</i> 1 GB <i>(Dual Core)</i>		
Non-volatile memory (FRAM)	100 kB		
Dimensions and weight			
Dimensions (WxHxD)	197 x 136 x 56 mm	259 x 177 x 56 mm	392 x 241 x 56 mm
Weight	approx. 2 kg	approx. 2,5 kg	approx. 3 kg
Operating conditions			
Operating temperature	If the installation are followed, this applies to the front and rear side of the device. 0 °C to 55 °C Single Core, 0 °C to 50 °C Dual Core		

Dialog Controller	Compact HMI Prime 7	Compact HMI Prime 10	Compact HMI Prime 15
Relative humidity	max. 85%, non-condensing		
Transport and storage			
Operating temperature	-20 °C to +70 °C		
Relative humidity	max. 85%, non-condensing		
Operation			
Installation	removable securing clips		
Certification	to product standards EN 61010-2-201, EN 61131-2		
Development environment	CODESYS V3 (IEC 61131-3)		
Protocols	Standard EtherCAT master, CANopen master Optional: Modbus RTU M/S, Modbus TCP M/S, SNMP, OPC UA, Ethernet/IP, PROFINET, BACnet		
Visualisation	Target Visu (Display), Web Visu (Web Server, HTML5)		
Touch operation	Touch capacitive (multi-touch)		
Shock resistance			
Vibration	sinusoidal (EN 60068-2-6) test: Fc 10...150 Hz, 10 m/s ²		
Shock	15 G (approx. 150 m/s ²), 11 ms duration, sinusoidal half-wave (EN 60068-2-27) Test: Ea		
EMC, protection rating			
Emitted interference	EN 61131-2 / EN 61000-6-3; EN55011 Class B group 1 (residential areas)		
Immunity to interference	EN 61131-2 (industrial zone)		
Protection class	III		
Insulation strength	EN 61131-2; 500 V DC test voltage		
Protection type	IP20 (front IP54)		
Power supply (24 V power)			
Supply voltage	+24 V DC (-15 % / +20 %) SELV max. ripple component 5%		
Power consumption	Max. 0.8 A (with 15" device max. 0.9A), peak current 1.5 A at +24 V DC fused		
Power consumption, dig. Outputs	Depending on the output load, max. 2 A continuous rating		

Dialog Controller	Compact HMI Prime 7	Compact HMI Prime 10	Compact HMI Prime 15
Protection against reverse polarity	yes		
Ethernet interfaces			
No. / type of interface	1x 10/100 Base T		
Connection system	RJ45		
EtherCAT interface			
No. / type of interface	1x EtherCAT (EtherCAT master)		
Connection system	RJ45		
CAN interface			
No. / type of interface	1x CAN-Bus		
Protocols	CAN-Bus, CANopen Master		
Serial interfaces			
No. / type of interface	1x RS-232 1x RS-485		
Protocols	Modbus RTU (option)		
USB interfaces			
No. / type of interface	2 x host USB 2.0 / USB connector port A		
No. plugging/unplugging cycles	max. 1000		
Additional functions			
Real-time clock	yes, with battery back-up		
microSD card slot	1x microSD card (optional)		
I/O			
Digital IN	4 x DI		
Digital OUT	4 x DO (0,5 A)		
Analog IN	4 x universal analogue inputs (-10 V...+10 V), 2x PT100 / PT1000 Resolution 24 bit		
Battery			
Type	Panasonic VL2020 or similar		

Dialog Controller	Compact HMI Prime 7	Compact HMI Prime 10	Compact HMI Prime 15
Lifespan	10 years (depending on the operating temperature)		
Storage	1 year without voltage (ex-works value without ageing; RTC data may be lost during longer storage periods)		

10.2. Device variations and identification

Name	Order no.	Features
Compact HMI Prime 7 S01	S-01010104-0104	7" Display + capacitive Touch + 1x Ethernet; 1x Ethercat; 2x USB; 512 MB RAM; Real time clock (with battery); 4x DI. 4x DO
Compact HMI Prime 7 S02	S-01010104-0204	Same as S01 + 4x analogue inputs
Compact HMI Prime 7 S03	S-01010104-0304	Same as S02 + 1x CAN Bus, RJ45; 1x µSD-Card Slot; 1 GB Flash
Compact HMI Prime 7 S04	S-01010104-0404	Same as S03 + 1x RS232/485 Kombi; additional 1 GB Flash (2 GB Flash in total)
Compact HMI Prime 7 S05	S-01010104-0504	Same as S04 + additional CAN Bus, RJ45
Compact HMI Prime 10 S01	S-01010104-0105	10,1" Display + capacitive Touch + 1x Ethernet; 1x Ethercat; 2x USB; 512 MB RAM; Real time clock (with battery); 4x DI. 4x DO
Compact HMI Prime 10 S02	S-01010104-0205	Same as S01 + 4x analogue inputs
Compact HMI Prime 10 S03	S-01010104-0305	Same as S02 + 1x CAN Bus, RJ45; 1x µSD-Card Slot; 1 GB Flash
Compact HMI Prime 10 S04	S-01010104-0405	Same as S03 + 1x RS232/485 Kombi; additional 1 GB Flash (2 GB Flash in total)
Compact HMI Prime 10 S05	S-01010104-0505	Same as S04 + additional CAN Bus, RJ45
Compact HMI Prime 15 S01	S-01010104-0108	15,6" Display + capacitive Touch + 1x Ethernet; 1x Ethercat; 2x USB; 512 MB RAM; Real time clock (with battery); 4x DI. 4x DO
Compact HMI Prime 15 S02	S-01010104-0208	Same as S01 + 4x analogue inputs
Compact HMI Prime 15 S03	S-01010104-0308	Same as S02 + 1x CAN Bus, RJ45; 1x µSD-Card Slot; 1 GB Flash
Compact HMI Prime 15 S04	S-01010104-0408	Same as S03 + 1x RS232/485 Kombi; additional 1 GB Flash (2 GB Flash in total)
Compact HMI Prime 15 S05	S-01010104-0508	Same as S04 + additional CAN Bus, RJ45

10.3. Options and Add-ons

Ordering of options is achieved in the following format: "Order number option1 option2 ..."

e.g.: **S-01010104-0204 S001 S002 H001**

In addition to the order number, further add-ons in the form of hardware, software and customer-specific options are marked as follows:

Option code	Option type
S000-S999	Software options e.g.: Fieldbus
H000-H999	Hardware options e.g.: Connector sets, certifications
C000-C999	Customer-specific options e.g.: Customer specific firmware, customer specific front (foil)

For more information about the options available for this device, please refer to our product catalogue or website.

The additional features included or installed in each device are listed on the options label. This label can be found on the device and/or on the packaging.



Abb. 4242: Options label

11. Standards and certificates

11.1. Standards

Applicable directives

- EMC directive 2014/30/EU
- RoHS directive 2011/65/EU

Applicable standards

- Standard
EN 63000:2019-05
- PLC standard
EN 61131-2:2008-4
- Emission standard
EN 61000-6-3:2012-11
- Safety provisions
DIN EN 61010-2-201

12. Appendix

12.1. Information on copyright and software licence

The firmware of the devices contains der free software. Parts of this software are available under the following OpenSource licences, amongst others:

- ➔ GNU General Public License (GPL)
- ➔ GNU Lesser General Public License (LGPL)
- ➔ Mozilla Public License (MPL)
- ➔ FreeType License (FTL)